

ULTIMATE
PRODUCTS INC.

INFRARED RADIANT HEATER
OWNER'S MANUAL

CAR WASH

SGX - SERIES

SA - SERIES

CW - SERIES

ER - SERIES

AL - SERIES

SC -SERIES

2319 Laurelbrook Street, Raleigh, NC 27604 USA
Phone: 800.542.7221 Fax: 919.834.4526
www.ultimate-products.com

-INDEX-

A. INSTALLATION INSTRUCTIONS	2
1. TECHNICAL DATA	2 – 4
(a) General Information	
(b) ER-Series heating Models (or GX, CW, AL, SC)	
(c) Typical Arrangement of Heater	
2. PACKAGING AND SHIPPING	4 – 5
3. MOUNTING CLEARANCES	5 – 6
4. PRE-ASSEMBLY	6
5. INSTALLATION	7
6. GAS CONNECTION	8 – 9
7. ELECTRICAL CONNECTION	10 – 11
8. VENT REQUIREMENT AND DETAILS	12 – 13
(a) Unvented units	
(b) Vertical Vent	
(c) Horizontal Vent	
9. FRESH AIR DUCTED INTAKE	13
(a) Vertical Thru Roof	
(b) Horizontal Thru Wall	
10. INSTALLATION CHECK OUT AND START UP	14 – 15
B. SERVICE AND MAINTENANCE INSTRUCTIONS	16 – 21
1. Servicing Instructions	
2. Routing Service	
3. Replacement of Components	
4. User Instructions	
C. Appendix 'A'	22-53
D. Appendix 'B'	54-56

Note: All reference to standard specifications, codes, regulations, etc., are intended to reflect latest editions included in the ANSI Testing, Construction, Performance and Installation Standards. (ANSI/ NFPA standard 1985)

WARNING: Improper installation, adjustment, alteration, service or maintenance can cause property damage, injury, or death. Read the installation, operating, and maintenance instructions thoroughly before installing or servicing this equipment.

A. INSTALLATION INSTRUCTIONS

A.1 TECHNICAL DATA

(a) General Information

Model & Heat Input

Information all units:

Gas Supply Connection: 1/2-inch NPT Male

Electrical Supply: 120V, 1 phase, 60Hz

Current Rating: 1.2 AMP MAX (Burner-0.3/Fan – 0.9)

Ignition: Electronic Program Start-up with Spark Ignition

OPTIONS:

1. Modify combustion chamber air intake for fresh air duct.
2. Ultimate Products Black Bulb Thermostat.
3. Control Panel with multi-zone capabilities. (Not A.G.A. Certified)
4. Individual Heater Vent to Exterior.

Notes:

- A. Heater is intended for heating non-residential indoor and outdoor spaces and should only be installed where flammable gases or vapors are not generally present.
- B. Indoor heaters may be suspended either horizontal or at an angle, or may be wall mounted. Outdoor heaters must be suspended horizontally. **SEE SECTION A.3 FOR CLEARANCES.**
- C. Installation shall conform with local building code requirements and with National Fuel code ANSI-Z223.1.A. (Latest Edition) and section 7.8A-3; Z223.1 (Latest Edition).
- D. The unit shall be electrically grounded in accordance with National Electric Code ANSI/NFPA 70-1987.
- E. The heater may be installed in aircraft hangars when conformation with ANSI/NFPA 409-1985 for Aircraft Hangars and in automotive garages when conforming with ANSI/NFPA 88A (Latest Edition) for Parking Structures and ANSI/NFPA 88B (Latest Edition) for Repair Garages.

Insure that minimum clearance will be maintained to vehicles parked below the heater.

Pipe Capacities For Propane and Natural Gas

Pipe Capacities For Propane in Thousands of BTUs Per Hour
 For pressure drop of 0.5" W.C., based on low-pressure piping based on 6 oz. per sq. in. pressure. Based on one Cubic Foot of Propane = 2500 BTUs.

SIZE PIPE INCHES	LENGTH OF STRAIGHT PIPE IN FEET															
	15	30	45	60	75	90	105	120	150	180	210	240	270	300	450	600
½	105	77.5	65	55	50	45	40									
¾	425	300	245	212.5	190	172.5	160	150	137.5	125	115	107.5	102.5	95	80	67.5
1	787.5	615	505	440	395	362.5	330	315	282.5	252.5	237.5	220	205	197.5	157.5	137.5
1¼	1542.5	1070	882.5	770	677.5	630	582.5	542.5	487.5	440	410	385	362.5	347.5	282.5	237.5
1½	2425	1700	1402.5	1212.5	1070	977.5	912.5	857.5	772.5	700	645	607.5	575	542.5	440	377.5
2	5040	3490	2835	2520	2205	2047.5	1890	1732.5	1575	1417.5	1322.5	1245	1165	1117.5	897.5	770
3	13545	9607.5	7875	6772.5	5985	5512.5	5197.5	4882.5	4252.5	3937.5	3622.5	3387.5	3232.5	3072.5	2520	2127.5
4	28035	19687.5	16222.5	14017.5	12600	11497.5	10710	9922.5	8820	8032.5	7560	6930	6615	6300	5040	4410

Pipe Capacities For Natural Gas In Thousands of BTUs Per Hour
 For pressure drop of 0.5" W.C. pressure. Based on one Cubic Foot on Natural Gas = 100 BTUs.

SIZE PIPE INCHES	LENGTH OF STRAIGHT PIPE IN FEET																				
	10	20	30	40	50	60	70	80	90	100	125	150	175	200	300	400	500	600	700	800	1000
½	170	118	95	80	71	64	60	55	52	49	44	40	37	34	27	23	21	19			
¾	360	245	198	169	150	135	123	115	108	102	92	83	77	71	57	48	43	39			
1	540	440	325	285	250	225	215	195	185	177	155	140	130	120	100	80	70	65	57	48	40
1¼	1125	790	660	570	510	465	440	410	390	375	355	305	280	260	205	180	165	140	125	115	100
1½	1700	1200	1000	865	780	720	670	620	600	570	510	455	430	400	315	265	240	215	195	180	150
2	3100	2225	1855	1600	1450	1375	1250	1175	1120	1075	970	880	820	760	610	530	470	420	390	365	320
2½	5040	3525	3000	2600	2350	2175	2025	1890	1810	1745	1570	1420	1315	1225	995	845	740	660	620	570	500
3	9100	6500	5300	4600	4435	3780	3530	3290	3140	3020	2905	2840	2450	2140	1640	1385	1210	1085	930	900	760
3½		9500	7880	6780	6140	5670	5280	4940	4685	4300	4000	3660	3380	3185	2500	2300	1890	1690	1545	1445	1245
4				9450	8500	7880	7325	6870	6550	6300	5600	5125	4760	4400	3145	3010	2870	2670	2400	2100	1800

A.1 TECHNICAL DATA (CONT.)

(c) Typical Arrangement of Heater

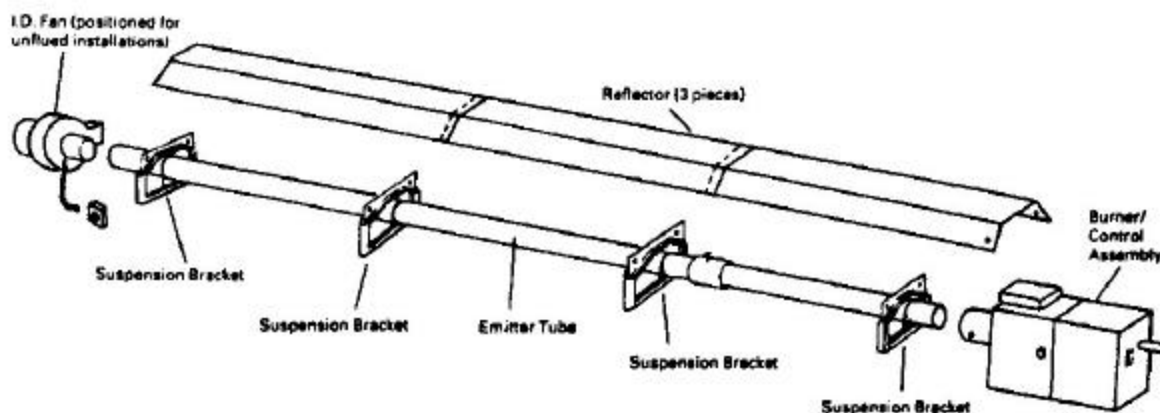

Straight Tube Heater

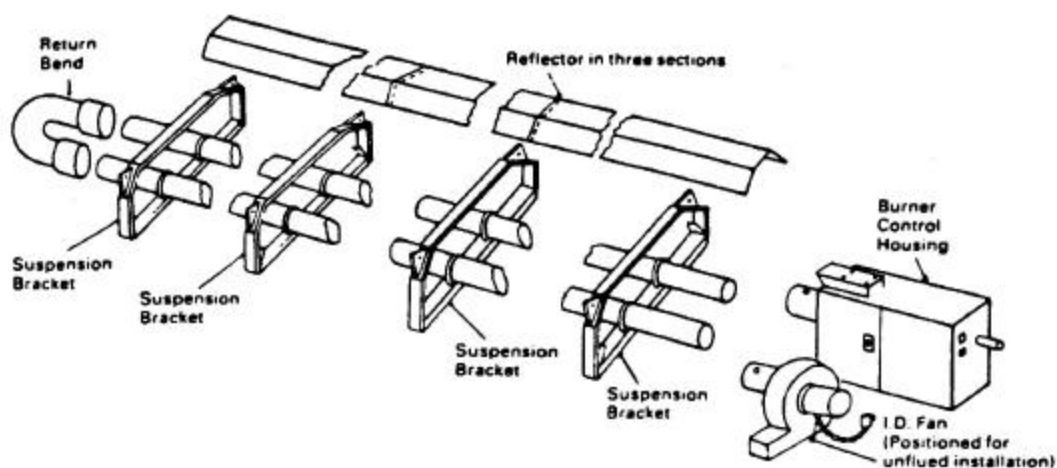

U-Tube Heater

A.2 PACKAGING AND SHIPPING INFORMATION

See Appendix 'A' for assembly drawings. Materials lists with part numbers and descriptions for each part will accompany each shipment.

Heaters include: Burner/Control
Radiant Tubes
Reflectors
Brackets
Vacuum Fan
U-Bend (U-Tube Units only)
Wiring Junction Boxes (Straight Tube Units Only)

A.2 PACKAGING AND SHIPPING INFORMATION (CONT.)

- Options:
- Fresh air Intake (Mounted to Burner/Control)
 - Fan Vent Adapters- Vertical and Horizontal
 - Thermostat
 - Flexible Gas Connector
 - Ball Valve
 - Vent Hoods
 - Hanging Assembly (chain, etc.)

Shipping packages for individual projects will be boxed and crated as outlined on the specific bill of lading.

A.3 MOUNTING CLEARANCES

The heater should be positioned so that clearances from combustible materials will meet or exceed those shown in the following table. Also, ensure that there is at least 6" clearance on all sides of burner for service access and for free flow of combustion air. When heater is angle mounted, the burner/control assembly must remain horizontal.

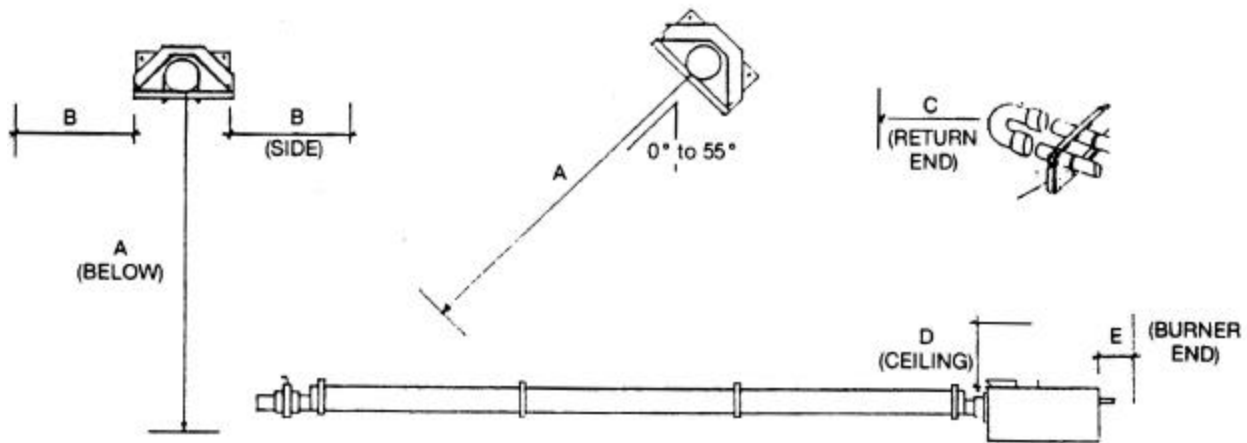

FIGURE 2: MINIMUM CLEARANCES TO COMBUSTIBLE MATERIALS

Minimum Clearances To Combustibles In Inches

Model	Input – BTU / HR	A	B	D	E
GH / ER / AL / SC 12	40,000	43	20	4	6
GH / ER / AL / SC 15	50,000	66	20	*	6
GH / ER / AL / SC 18	60,000	66	20	*	6
GH / ER / AL / SC 22	75,000	66	20	*	6
GH / ER / AL / SC 29	100,000	72	30	12	6
GH / ER / AL / SC 38	130,000	72	30	12	6
GH / ER / AL / SC 44	150,000	93	36	12	6

A.3 MOUNTING CLEARANCES (CONT.)

Mounting Position	MOUNTING HEIGHT ABOVE FLOOR		
	40,000 – 75,000 B.T.U	100,000 – 130,000 B. T. U.	150,000 B. T. U
<u>Horizontal</u> Recommended Minimum	14 ft 12ft	16ft 14ft	18ft 16ft
<u>Inclined</u> Recommended Minimum	11ft 10ft	13ft 12ft	15ft 14ft

Ensure that there is adequate provision in the building for combustion and ventilating air supply. Installation must meet minimum requirements of applicable codes.

When installed in public garages and airplane hangars ensure that minimum clearances specified in ANSI/NFPA 88A or B, ANSI/NFPA 409, respectively, are met; and in no case less than those in the preceding tables.

A.4 PRE-ASSEMBLY

Each heating unit is assembled as follows:

Note that the emitter tube consists of more than one tube. The tube to be connected to the burner box is the thinner stainless steel or aluminized steel tube. Other tubes may be mild (thicker tubes), stainless or aluminized steel. Connections between tubes is by a coupling with three bolts. The coupling has an inner compression sleeve that holds the pipe securely when the nuts are turned tight.

Support the assembled radiant tube with screws facing upwards, on blocks, etc. at least 6” above floor level, preferably under the position of installation. Ensure that the tube is clear internally.

Slip the suspension brackets onto the tube assembly and attach by means of “U” bolts and nuts. Note that there are two types of brackets; type C and type B. Type C attaches reflectors together. Bracket C & B are placed on the assembled radiant tube in position shown on the assembly drawing in APPENDIX “A”. Tighten nuts to secure brackets to the tubes at spacing indicated with all brackets oriented in the same level position.

NOTE: CLOSE ALL S-HOOKS TO INSURE THAT THE CHAINS DO NOT COME OFF OF THE HOOK.

A.5 INSTALLATION

Heater units: At this point raise the tube assembly into position and suspend from previously fixed chains (9 gauge min. galvanized welded link construction), or attach to wall mounting brackets. Wall mounting brackets must support heater at an angle of inclination of $45^{\circ} \pm 10^{\circ}$. Longer tube assembly may be raised in more than one sub-assembly with final tube connection made in the air.

It is recommended that the heater be suspended to slope slightly downward from the burner approximately 1 inch in 20 feet, but not more than 2-inches total.

Remove the protective plastic film from the reflector surface. Note that each section of reflector has two holes punched at one end. This end is firmly fixed by bolting to the lugs provided on the reflector bracket type C. The other end of each reflector section is free floating in suspension bracket type B thereby allowing for thermal expansion.

Position reflector sections so that ends with holes lap at type C brackets and secure with nuts, bolts, and large washers provided in the burner box crate. Reflector should be allowed free movement through brackets type B. Note: Reflectors may be installed before tube is raised to position at installer's option.

Slide burner/control assembly onto the burner end of the radiant tube ensuring it is fully engaged and upright, (i.e. with air inlet cover plate facing upwards) and secure with locking screws provided.

Slide the fan assembly on the opposite end of radiant tube, ensuring that it is fully engaged with fan outlet facing horizontally for outdoor installations and for indoor installations either unvented or with horizontal thru wall venting. Fan outlet should face upward for vertical venting thru the roof.

A.6 GAS CONNECTION

The gas connection on the heater is ½” NPT external thread.

SERVICE REQUIREMENTS	NAT. GAS	L.P. GAS
Max. inlet gas supply pressure (in.w.c.)	10.0	14.0
Min. inlet gas supply pressure (in.w.c.)	6.5	11.0

Injector sizes and manifold pressure for the burner are shown in the attached table for all heater units.

The gas supply piping and connections must be installed so that the minimum pressure stated is achieved.

A gas shut-off valve and union should be fitted in the gas supply line close to the heater, and a 1/8 inch N.P.T. plugged tapping, accessible for test gauge connection, provided immediately upstream of the appliance gas inlet.

It is essential to provide some flexibility in the final gas connection preferably by use of an approved armored flexible connector or stainless steel expansion loop. (See Appendix 'A')

Model Designation			Air Inlets (Inches/ Millimeters)			Natural Gas Orifice		Liquid Petroleum Orifice	
	Input KW BTU/HR	Model Tube Configuration	Tube Dia. (In)	Burner Intake (in. / M.M.)	Fan Inlet (in. / M.M.)	Injector Diameter (inches)	Manifold Pressure (in.W.C.)	Injector Diameter (inches)	Manifold Pressure (in./mm)
GH/ER/AL/SC	12/40,000	S-20	3"	1.125"/29mm	1.312"/33mm	0.130"	1.9	0.080"	6.7
		S-25	3"	1.125"/29mm	1.438" /37mm	0.130"	1.9	0.080"	6.7
		S-30	3"	1.125"/29mm	1.438" /37mm	0.130"	1.9	0.080"	6.7
		U-20	3"	1.125"/29mm	1.187/30mm	0.130"	1.9	0.080"	6.7
		U-30	3"	1.125"/29mm	1.187/30mm	0.130"	1.9	0.080"	6.7
GH/ER/AL/SC	15/150000	S-20	3"	1.312"/33MM	1.438"/37 MM	0.130"	3	0.080"	6.7
		S-25	3"	1.125"/29 MM	1.438"/37 MM	0.130"	3	0.080"	6.7
		S-30	3"	1.125"/29 MM	1.438"/37 MM	0.130"	3	0.080"	6.7
		U-20	3"	1.312"/33MM	1.438"/37 MM	0.130"	3	0.080"	6.7
		U-30	3"	1.312"/33MM	1.312"/33 MM	0.130"	3	0.080"	6.7
GH/ER/AL/SC	18/60,000	S-20	3"	1.750"/44 MM	2.00"/50 MM	0.161"	2.4	0.098"	6.7
		S-25	3"	1.312"/33 MM	1.438"/37 MM	0.161"	2.4	0.098"	6.7
		S-30	3"	1.312"/ 33 MM	1.438"/37 MM	0.161"	2.4	0.098"	6.7
		S-40	3"	1.312" /33 MM	1.438"/37 MM	0.161"	2.4	0.098"	6.7
		S-20	3"	1.312" /33 MM	1.750"/44MM	0.161"	2.4	0.098"	6.7
		S-30	3"	1.312" /33 MM	1.438"/37 MM	0.161"	2.4	0.098"	6.7
		S-40	3"	1.312" /33 MM	1.312"/33MM	0.161"	2.4	0.098"	6.7
GH/ER/AL/SC	22/75,000	S-20	3"	1.750"/44 MM	2.625"/67 MM	0.161"	3.8	0.098"	10.5
		S-25	3"	1.750"/44 MM	2.00"/50 MM	0.161"	3.8	0.098"	10.5
		S-30	3"	1.750"/44 MM	2.00/50 MM	0.161"	3.8	0.098"	10.5
		S-40	3"	1.750"/44 MM	1.75"/44MM	0.161"	3.8	0.098"	10.5
		U-20	3"	1.750"/44 MM	2.625"/67 MM	0.161"	3.8	0.098"	10.5
		U-30	3"	1.750"/44 MM	2.00/50 MM	0.161"	3.8	0.098"	10.5
		U-40	3"	1.750"/44 MM	2.00/50 MM	0.161"	3.8	0.098"	10.5
GH/ER//SC	29/100,000	S-40	4"	2.312"/59 MM	2.00"/50 MM	0.182"	4.9	1.20"	10
		S-50	4"	2.312"/59 MM	2.00"/50 MM	0.182"	4.9	1.20"	10
		S-60	4"	2.312"/59 MM	2.00"/50 MM	0.182"	4.9	1.20"	10
		U-35	4"	2.312"/59 MM	2.00"/50 MM	0.182"	4.9	1.20"	10
GH/ER/AL/SC	38/130,000	S-40	4"	2.312"/59 MM	2.625"/67MM	0.206"	4.9	0.136"	10
		S-50	4"	2.312"/59 MM	2.625"/67MM	0.206"	4.9	0.136"	10
		S-60	4"	2.312"/59 MM	2.625"/67MM	0.206"	4.9	0.136"	10
		U-35	4"	2.312"/59 MM	2.625"/67MM	0.206"	4.9	0.136"	10
SC/ER/GX	44/150,000	S-40	4"	2.312"/59 MM	4.00"/100MM	0.228"	4.6	0.149"	10
		S-50	4"	2.312"/59 MM	4.00"/100MM	0.228	4.6	0.149"	10
		S-60	4"	2.312"/59 MM	4.00"/100MM	0.228	4.6	0.149"	10
		U-35	4"	2.312"/59 MM	4.00"/100MM	0.228	4.6	0.149"	10

A.7 ELECTRICAL CONNECTION

(a) Burner/Control Internal Wiring

IMPORTANT: All electrical work should be done by a qualified electrician in accordance with the National Electrical Code ANSI/NFPA 70.

Supply: 120 V, 60 Hz, single phase
Current Rating: 0.3 amp max

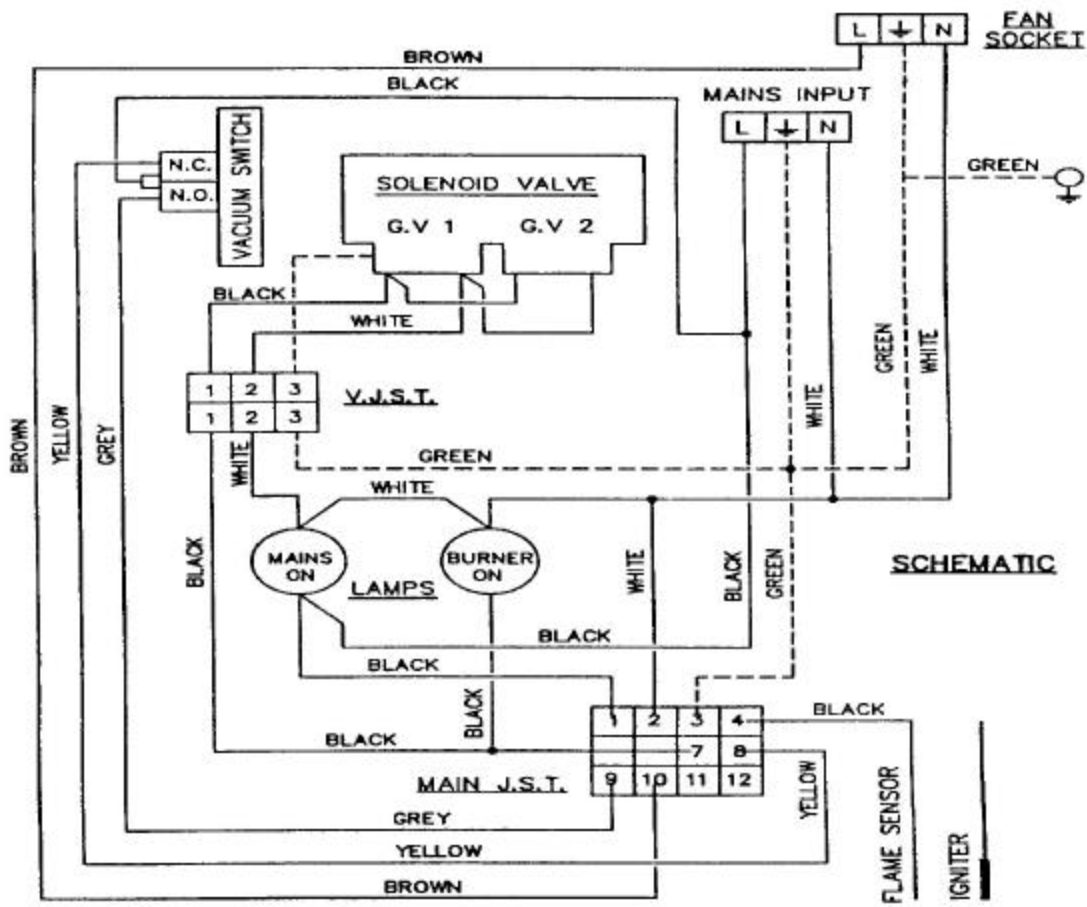

A.7 ELECTRICAL CONNECTION (CONT.)

The electrical supply to the heater is by three wires: live, neutral and ground connections. It is recommended that the supply cable be in metallic conduit to the 3/4" hole provided.

Power is **ONLY** supplied to the terminal in the back of burner as shown below:



Power is supplied to fan through the knock out on the side of the burner housing.

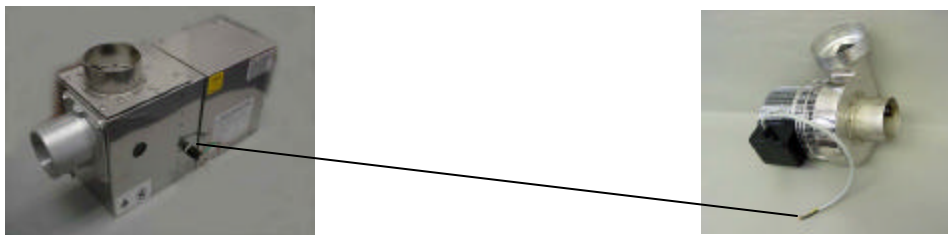

Fan leads should be connected to the burner leads using the wire nuts provided. Connect yellow/green wire from fan, to green wire of the burner, connect either black wire from the fan, one to the white and one to the black/brown of burner. Insure that conduit clamp is firmly tightened.

It is recommended that the electrical circuit controlling the heater or group of heaters include thermostats, a time switch and if required manual control switches. All such controls and switch gear must be rated to handle the total inductive load of the circuit they control. For large installations, the use of relays or contractors should be considered.

Control panels are available from the manufacturer incorporating multiple Black Bulb Thermostats controlling up to 10 heaters per thermostat for zone control of the heated area. Typical External Wiring is shown in diagram. (Control panels are not A.G.A. design certified.)

A. 8 VENT REQUIREMENTS AND DETAILS

- (1) **UNVENTED UNITS:** Heaters may be installed without a flue providing the governing building codes are met and that consideration is properly given to possibilities of condensation on cold surfaces.

Installation shall meet the following requirements when unvented:

- (A) Internal volume of the heated room must be greater than 214 cu. ft. per 100 BTU/HR of heaters installed.
 - (B) Natural or mechanical means shall be provided to supply and exhaust at least 4 CFM per 1,000 BTU per hour input of installed heaters.
 - (C) Combustion gases shall not impinge on combustible materials with a temperature in excess of 150° F.
 - (D) The blower discharge must be horizontal.
- (2) **VERTICAL VENTING:** The heater may be installed with a vertical flue. A down vent elbow must be fitted to the induced draft fan exhaust outlet, which should be rotated to a vertical position.

A vent elbow designed to accept a 6-inch nominal sheet metal flue pipe is available as an optional extra.

All flue piping should be adequately supported from the building structure and terminated with an approved terminal. The maximum flue length is 30 ft. with a maximum of two bends. All connections should be properly sealed. Generally, terminal may be located horizontally a dimension equal to its vertical dimension.

- (3) **HORIZONTAL VENTING:** Individual units may be vented horizontally through side walls. Venting must be installed in accordance with ANSI Z2223.1 (NFPA-54) and local codes.

Maximum length of vent is 25 ft. with 2-90 degree long radius elbows.

Runs of 12 ft. or shorter can use 4-inch diameter flue with Ultimate Products part number V0200.

Runs over 12 ft. should use 6-inch dia. flue pipe. Any portion of flue that passes through a combustible wall must be insulated or use an approved insulating thimble.

Recommended parts are Ultimate Products' (Part # V-0200) for 4-inch flue and (Part # V-0800) for 6-inch flue. Standard vent terminals must extend at least 6-inches from the wall and at least 24-inches from any combustible overhang. Protect the building material from degradation by flue gases.

A.8 VENT REQUIREMENTS AND DETAILS (CONT.)

Flue joints should be sealed using RTV high temperature sealant and secured using at least three (3) sheet metal screws. Should condensation occur flue should be shortened or insulated.

The terminal must exit the building at least 7 ft. above any area accessible to the public.

The terminal must be at least 3ft. away from any air intake to the building.

If the heater is equipped with ducted combustion air, the terminal must be at least 3 ft. away from the air inlet and located higher than the inlet.

The vent terminal must be protected from blockage by snow.

A.9 FRESH AIR DUCTED INTAKE

Whenever the heater is installed in locations where air born dust or other polluted atmosphere is present; a fresh air supply should be ducted to the burner.

A heater modified for fresh air intake should be specified when ordering. This model is modified with a 4-inch diameter duct connection at the burner.

A fresh air duct of 4-inch diameter should be installed from the fresh air to the air intake connection on the burner housing. A flexible jointing piece should be installed at the burner connection with hose clamps to facilitate the disconnection when servicing the burner assembly.

The maximum recommended length of fresh air duct is 25 feet and the maximum number of bends is two (2). The minimum length is 18 inches. The location of the fresh air duct inlet must be where it will receive dust free clean air. An Ultimate Products inlet cap with bird screen must be fitted at the inlet of the duct. If the duct inlet is located above the roof the underside of the inlet terminal must be at least 2 ft. above roof level and at least 10 inches above any projection on the roof within 7 ft. of the inlet.

See Appendix 'A' for typical installation drawing and Ultimate Products part numbers. Intake pipe, fittings, and sealant **are not** furnished by Manufacturer.

A.10 INSTALLATION CHECK OUT AND START UP

Inspect installation and ensure that it has been carried out in accordance with these instructions. Ensure that electrical and gas supplies are isolated.

The gas supply should be purged and tested for soundness in accordance with Local and National Safety codes.

Open isolating gas valve and test gas connections for soundness using soap solution.

Remove burner cover plate by unscrewing 6 screws. Take care not to damage the sealing gasket. Inspect the burner and electrode assemblies ensuring these are securely fixed and all electrical connections securely made. Replace the burner cover plate ensuring that the sealing gasket is correctly positioned and the six screws are fully tightened. The heater will not operate until this plate is refitted.

Remove the control housing cover plate by unscrewing the five securing screws.

Ensure all internal components are securely fixed and all connections securely made. Open the manual gas valve.

Switch on the electrical supply to the heater and observe the correct start up sequence. Ensure that the settings of any time switch and thermostat are such that the heating system will be required to operate.

The fan will start to run and "Power On" lamp will illuminate. Safe-start checks are carried out automatically.

After the fan has run up to full speed and a satisfactory vacuum condition has been established, ignition sequence will commence. The spark ignition will be energized producing a spark at the ignition electrode. The gas valve will at the same time be energized.

If the ignition is successful the flame sensing probe and the ignition spark is switched off. The 'burner on" lamp indicates that the gas solenoid valve is energized.

If ignition is unsuccessful the gas valve will close and the spark ignition de-energized after approximately 6 seconds. For approximately 10 to 20 seconds the fan will purge the system then re-ignition will be attempted. After three (3) attempts at ignition the control unit will "lock-out" - the "power on" lamp will remain illuminated and the fan will continue to run. To reset after "lock-out" switch off the power supply to the system and wait 5 minutes. Then turn the power on. If repeated "locked-out" occurs investigate the cause.

A.10 INSTALLATION CHECK OUT AND START UP (CONT.)

To shut down the heater, switch off the power supply to the system. Automatic control of the heater or a series of heaters may be achieved by incorporating thermostats, time switches, manual over-ride switches etc. in the electrical supply to the heater(s). It is essential to allow a delay of 15 seconds after switching off the system before attempting to restart.

If at any time after completion of the start up sequence, loss of flame should occur, the control unit will attempt to reignite. If this is unsuccessful lock out will occur.

Set burner gas pressure as follows. Switch off the power supply to the heating system. Connect a 'U' tube manometer to the pressure test nipple provided on the combination gas control valve. Remove the cover from the pressure regulator revealing the adjustable screw. Start the heater and using a suitable screwdriver adjust the pressure regulator, turning the screw clockwise to increase the pressure or counter clockwise to decrease the pressure. Set the pressure to appropriate in w.c. from the table of dimensions for correct heater description. Switch off the power supply to the heating system. Disconnect 'U' tube manometer and securely replace screw in pressure test nipple. Replace cover screw on pressure regulator.

Check the operation of the flame safeguard equipment as follows: With the heater running normally, switch off the gas supply at the shut off valve. The heater should attempt to relight and if the gas valve has been left off "lockout" should occur indicated by the "Power On" light only being illuminated and fan running.

Check the operation of the vacuum proving switch as follows. With the heater running normally, pull off the silicone rubber tube connecting the vacuum switch to the combustion chamber. Within one second, the burner should shut off. Then replace the tube securely and observe that the heater proceeds to ignite in the normal way.

Replace the controls cover securing the five fixing screws.

B. SERVICE AND MAINTENANCE INSTRUCTIONS

B.1 SERVICING INSTRUCTIONS

Under normal working conditions, it is recommended that the Ultimate Products Heater should be serviced annually. In exceptionally dirty or dusty conditions such as may occur in a foundry, more frequent servicing may be desirable. Servicing work should be carried out by a qualified gas service engineer.

IMPORTANT:

1. Never rest anything, especially ladders, against the heater.
2. Turn off gas and electrical supplies before servicing or repair work is started.
3. Unless otherwise instructed, reassemble parts in reverse order to the following instructions.

B.2 ROUTINE SERVICE

A. FAN – Inspect the main fan propeller and remove any dust brushing with a soft brush. Similarly remove any dust from the finger guard covering the secondary (cooling) impeller and the mesh aperture in the motor cover. Ensure that the impeller turns freely and that there is not excessive play in the bearings.

B. EMITTER TUBE – Brush away any dust on the exterior of the emitter tube. Inspect the emitter tube internally by removing the burner control box as directed in “D” below. If there is any appreciable build up of dust or deposits, the tube should be cleaned internally. The emitter tube may be cleaned by use of an industrial vacuum cleaner with a long extension tube, which is passed down the emitter tube.

Replace the burner/control assemblies engaging them fully on their tubes and secure by tightening the screws ensuring that they are squarely positioned (i.e. with the air inlet cover plate facing upwards).

C. REFLECTOR – The condition of the reflector should be noted and any necessary cleaning performed. The reflectors can be simply removed for cleaning by removing the reflector clamp screws securing them to the suspension brackets and sliding them out of the suspension brackets. The reflector can be cleaned with a soft cloth and detergent in water.

A mild non-abrasive metal polish may be used in cases of extreme discoloration.

D. REMOVAL OF BURNER/CONTROL ASSEMBLY – Remove the burner/control assembly by disconnecting the gas and electrical supply (and fresh air inlet duct if fitted). Slacken the burner fixing screws and draw the assembly off the emitter tube.

E. BURNER NER/ELECTRODE ASSEMBLY – Inspect the burner/electrode assembly by removing the six screws securing the combustion chamber cover plate to top of control box, taking care not to damage the sealing gasket. Remove the burner head by unscrewing it from the injector taking care not to drop it on the leads of the ignition electrodes. Replace the electrode assembly if it is not in good condition. The assembly is removed by removing the screws which attach it to the bracket on the front wall of the combustion chamber. The assembly is then lifted out of the combustion chamber and the cable disconnected. If the electrode assembly is in good order check the spark electrode gap, this should be .125 inches \pm .030 inches. Adjust the gap if necessary by bending the ground rod. Ensure the electrical connections are secure.

Inspect the injector and clean as necessary using a soft bristle brush. To remove or replace the injector, with the burner head removed, unscrew the injector from its carrier using a wrench, on the hexagon portion of its body. When replacing the injector ensure that it is fully tightened in its carrier. **(TIGHTEN SNUG -- DO NOT OVERTIGHTEN)**

Replace the burner head. Replace the combustion chamber top cover, renewing the rubber sealing gasket if this is not in good condition.

Inspect the burner fresh air inlet duct if fitted and ensure that it is free of any blockage or obstruction. Inspect the air inlet terminal and ensure this is not liable to obstruction.

Recheck the heater by following the procedure for check out and start up, taking care to check that the burner gas pressure is correctly set, and that the vacuum switch and flame safeguard equipment function correctly.

F. AUXILIARY CONTROLS – Check that auxiliary controls such as room thermostats, time switches, etc. function correctly and are set to operate at the desired temperatures. Ensure that the user is aware of the functions of the auxiliary controls and their correct settings. For most efficient operation of the heating system the time switch, if fitted, should be set to switch on normally between ¼ hour and 1 hour before commencement of occupancy of the building depending on local conditions. The correct setting of the room thermostat can only be determined by experience in cold weather when it should be set to shut off the heaters when a comfortable level of warmth has been achieved. This setting will normally be several degrees below that which would be required with a convective heating system.

B. 3 REPLACEMENT OF COMPONENTS

 **WARNING: TURN OFF GAS AND ELECTRICAL SUPPLIES BEFORE STARTING REPAIR WORK.**

- A. TO REPLACE ANY COMPONENTS IN THE BURNER/CONTROL ASSEMBLY** – This assembly should be removed from the heater by disconnecting the gas and electrical supplies (also the fresh air intake duct if used). Loosen the bolts and slide the burner/control assembly from the emitter tube.
- B. TO REPLACE ELECTRODE ASSEMBLY** – Remove top cover of combustion chamber by removing six (6) screws. Remove the screws securing the electrode assembly and pull off the electrode cable connector. Reconnect the cable connector to the new electrode assembly and replace the assembly. Replace the cover plate and gasket. Spark electrode gap $.125 \pm .030$ ".
- C. TO REPLACE THE BURNER HEAD** – Remove combustion chamber cover as in section B above. Unscrew burner head from injector. Screw on new burner head. Replace combustion chamber cover.
- D. TO REPLACE THE INJECTOR** – SEE PAGE 17
- E. TO REPLACE COMBINATION GAS VALVE** – Remove combustion chamber cover as in paragraph B. Remove control housing cover. Remove burner head as in paragraph C. Unscrew the gas supply pipe entering the combination gas valve. Remove the electrical connections from the valve. Remove the two (2) screws holding the gas valve. The combination gas valve can now be removed.

Replace any defective component and reassemble using approved pipe joining compound on pipe threads.

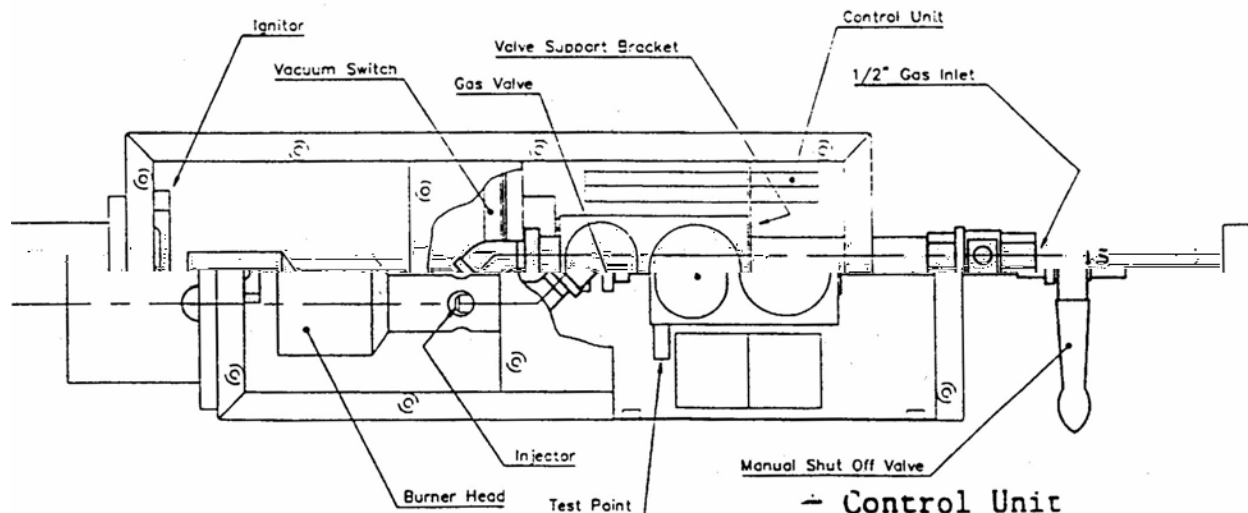

BURNER/CONTROL UNIT (FROM ABOVE)

- F. TO REPLACE THE BURNER/CONTROL UNIT** – Remove the control housing cover. After observing their positions, disconnect the wires to the burner control unit. Remove the screws securing the burner control unit to the base of the control housing. Remove the burner control unit. Install replacement unit, observing correct positions for color coded cables.
- G. TO REPLACE THE VACUUM SWITCH** – Remove the burner control unit as in paragraph F. Disconnect the rubber tube connection at the vacuum switch. Disconnect push on connectors from the vacuum switch. Remove the screws securing the vacuum switch and slip the switch out of its bracket. Installing is the reversal of the above taking care to correctly reconnect the cables.
- H. TO REPLACE THE RELAY** - Remove control housing cover. The relay is a plug-in type and can be changed without removing any other components. However, if necessary, remove the burner control unit to gain better access to the relay.

B.4 USERS INSTRUCTIONS

Hand the Users Instruction to the user and explain how to operate the heater.

Leave the Installation and Servicing Instructions with the service maintenance engineer or manager for use on future service calls.

USER INSTRUCTIONS

ULTIMATE PRODUCTS TUBULAR RADIANT HEATERS

Ultimate Products is the distributor of a series of tubular infrared heaters designed for overhead heating of industrial and commercial buildings. Individual heating units are suspended from the roof or mounted at an angle on the wall when inside buildings or horizontal when outside.

IMPORTANT

1. This appliance must only be installed by qualified craftsman in accordance with the requirements of local and national codes.
2. This appliance must be grounded in accordance with the National Electrical code ANSINFPA No.70.
3. Never rest anything, especially ladders, against the heater.

TO START THE HEATER

1. First ensure that the gas supply to each heater is turned on by opening main gas shut-off valve and manual valve on combination control.
2. Ensure that the settings of any time switch and thermostat are such that the heating system will be required to operate.
3. Switch on the electrical supply to the heater. The fan will start, the "Power On" light on the burner will illuminate and ignition will commence.
4. Ignition will occur and the burner light, colored orange, will illuminate.
5. If ignition is unsuccessful the gas valve will close and the spark igniter de-energize after approximately six (6) seconds. For approximately 10 to 20 seconds the fan will purge the system then re-ignition will be attempted. After three (3) attempts at ignition the control unit will lockout, the "power-on" lamp will remain illuminated and the fan will continue to run. To reset after "lockout", switch off the power supply to the heater and wait 5 minutes. Then turn the power on. If repeated "lockout" occurs investigate the cause.

TO SWITCH OFF THE HEATER

Switch off the electrical supply. The burner will shut off and the fan will stop.

SERVICING

To ensure continued efficient and safe operation it is recommended that the heater be serviced regularly by a qualified person, e.g. every year in normal working conditions but in exceptionally dusty or polluted conditions more frequent servicing may be needed.

Appendix A

VERTICAL VENT REQUIREMENTS FOR INDIVIDUAL HEATER

"CATEGORY III TYPE VENT" FOR SINGLE OR DOUBLE WALL VENT PIPING

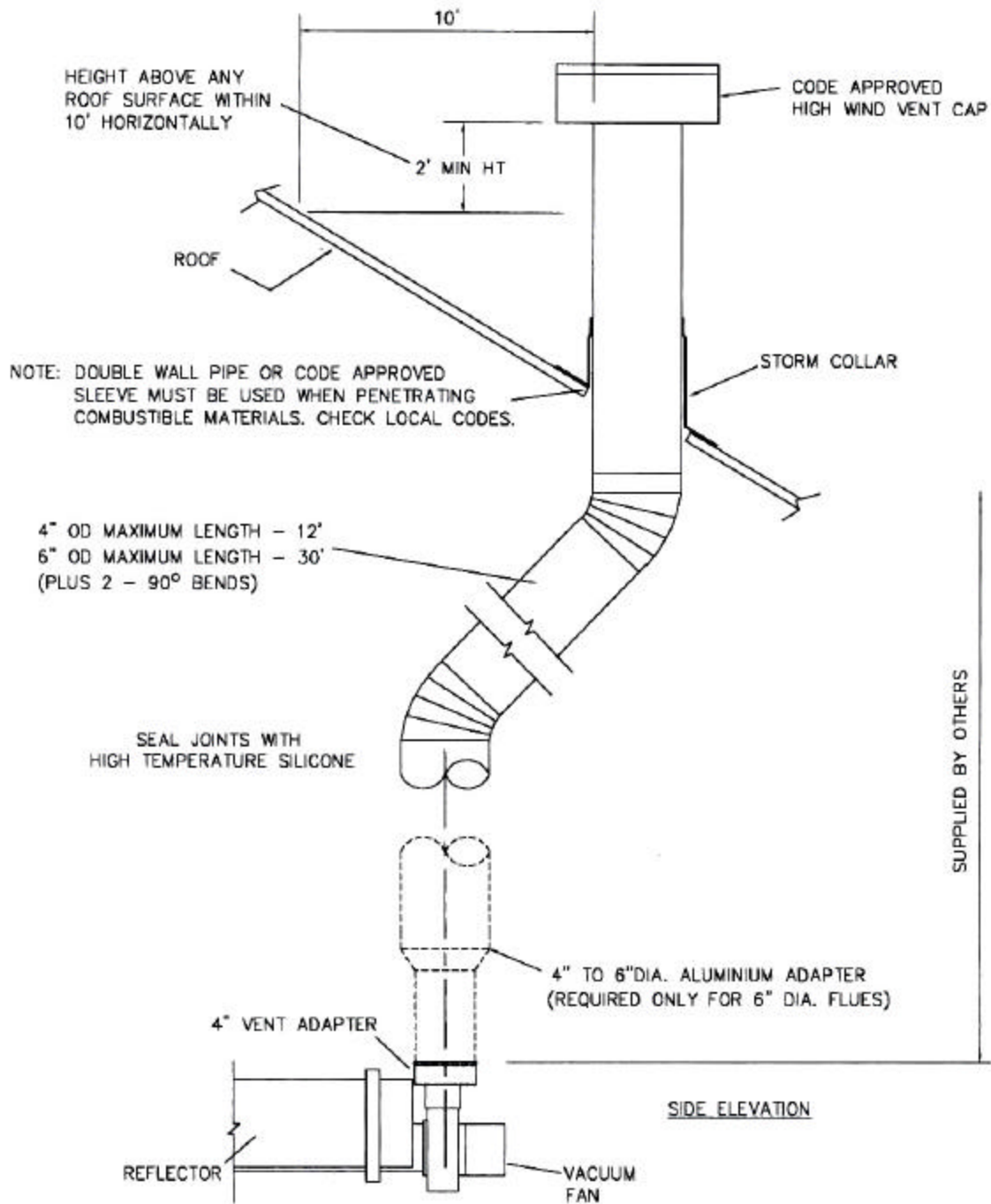

HORIZONTAL VENT REQUIREMENTS FOR INDIVIDUAL HEATER

"CATEGORY III TYPE VENT"
FOR SINGLE OR DOUBLE WALL VENT PIPING

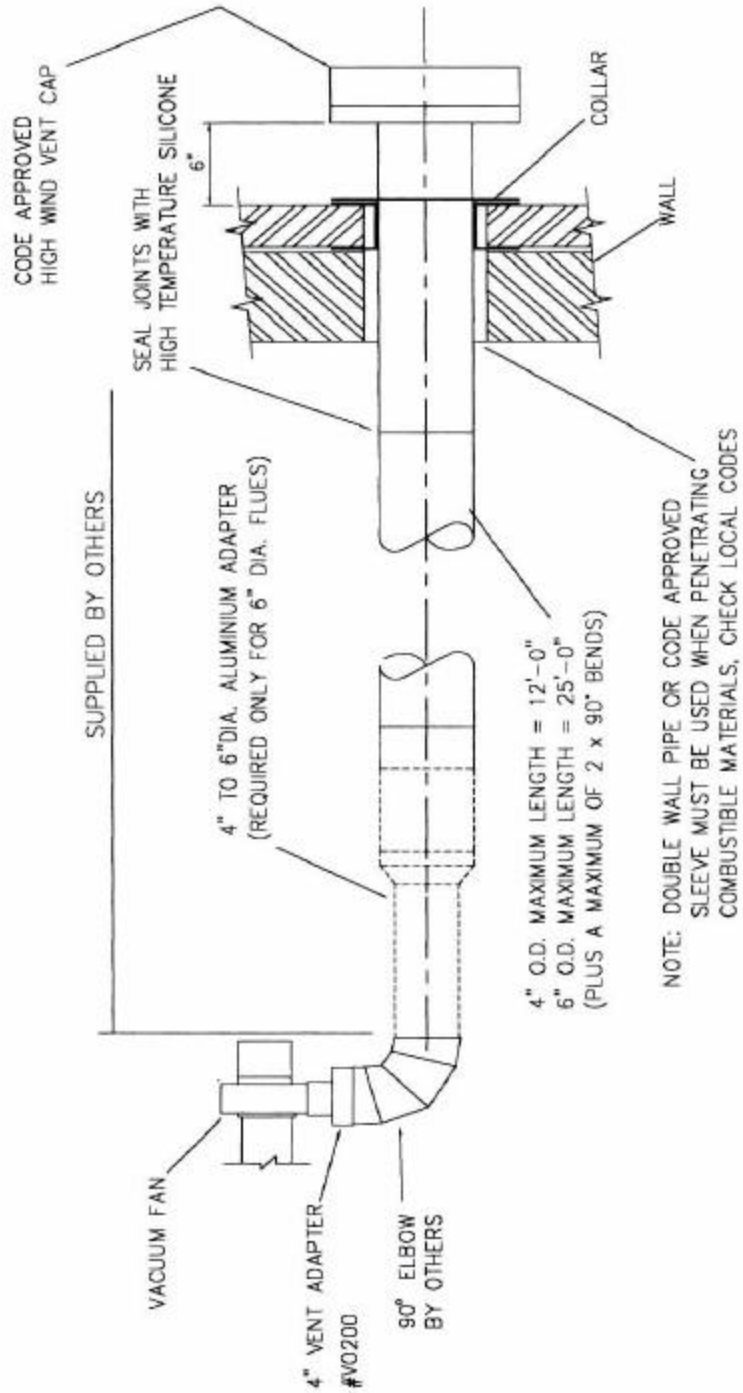

PLAN VIEW

OUTSIDE COMBUSTION AIR REQUIREMENTS, SIDE WALL APPLICATION

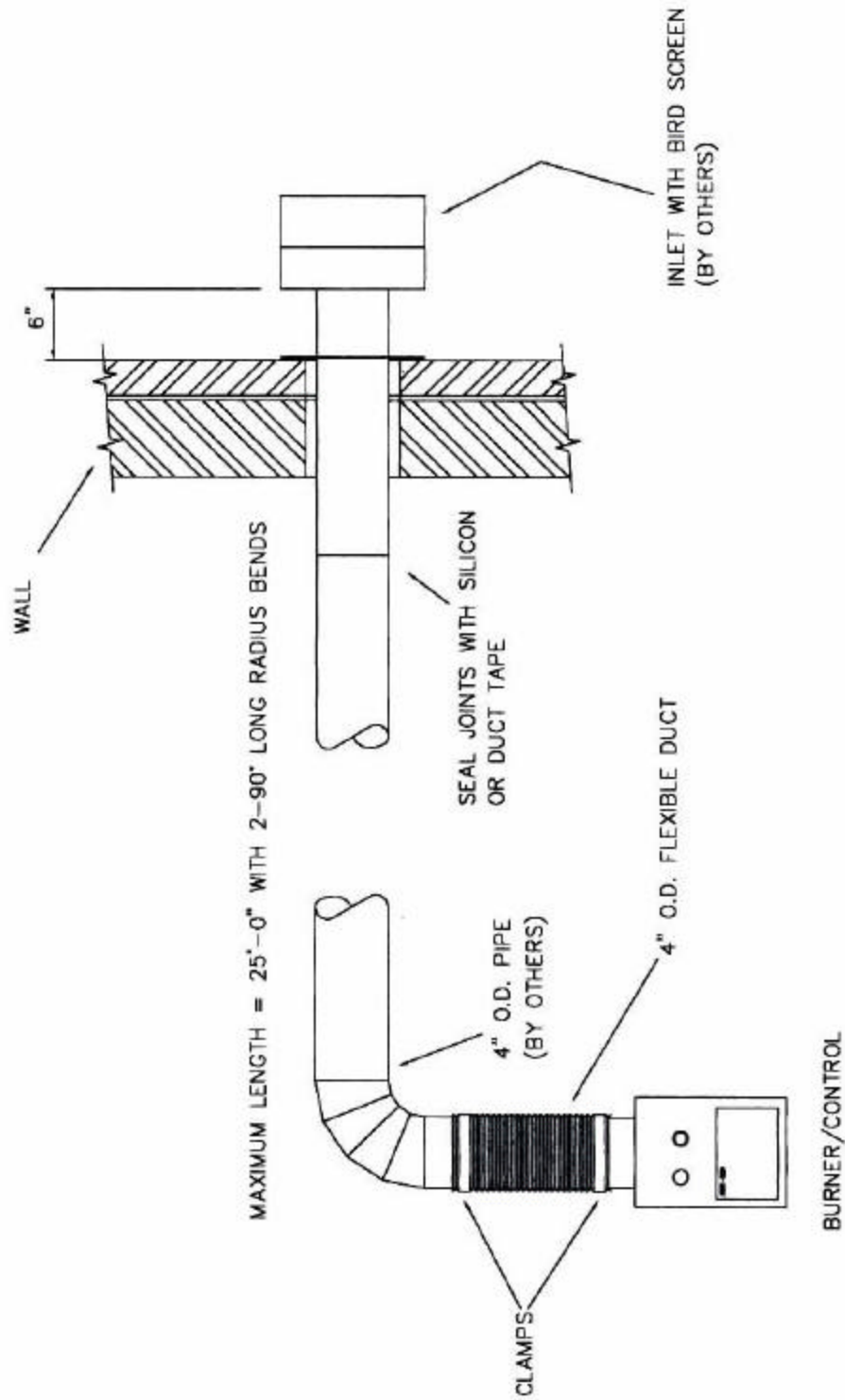

NOTE: AIR INLET MUST BE LOCATED A MINIMUM OF 3' FROM ANY BUILDING EXHAUST OR FLUES

LEGEND

0.25 BSSR	0.25" INSULATED FEMALE RECEPTACLE
1.0 BTL	1.0mm ² NON-INSULATED BOOTLACE TERMINAL
2BA RSE	2BA RED SHROUDED EYELET
0.187 BSSR	0.187" INSULATED FEMALE RECEPTACLE
0.25 NIFR	0.25" NON-INSULATED FLAG TERMINAL
5 NIFB	5mm NON-INSULATED FEMALE BULLET
WIRE SPECS: ALL ~ 18 A.W.G. UL 1015	
WIRE LENGTH TOL:	+10 / -0

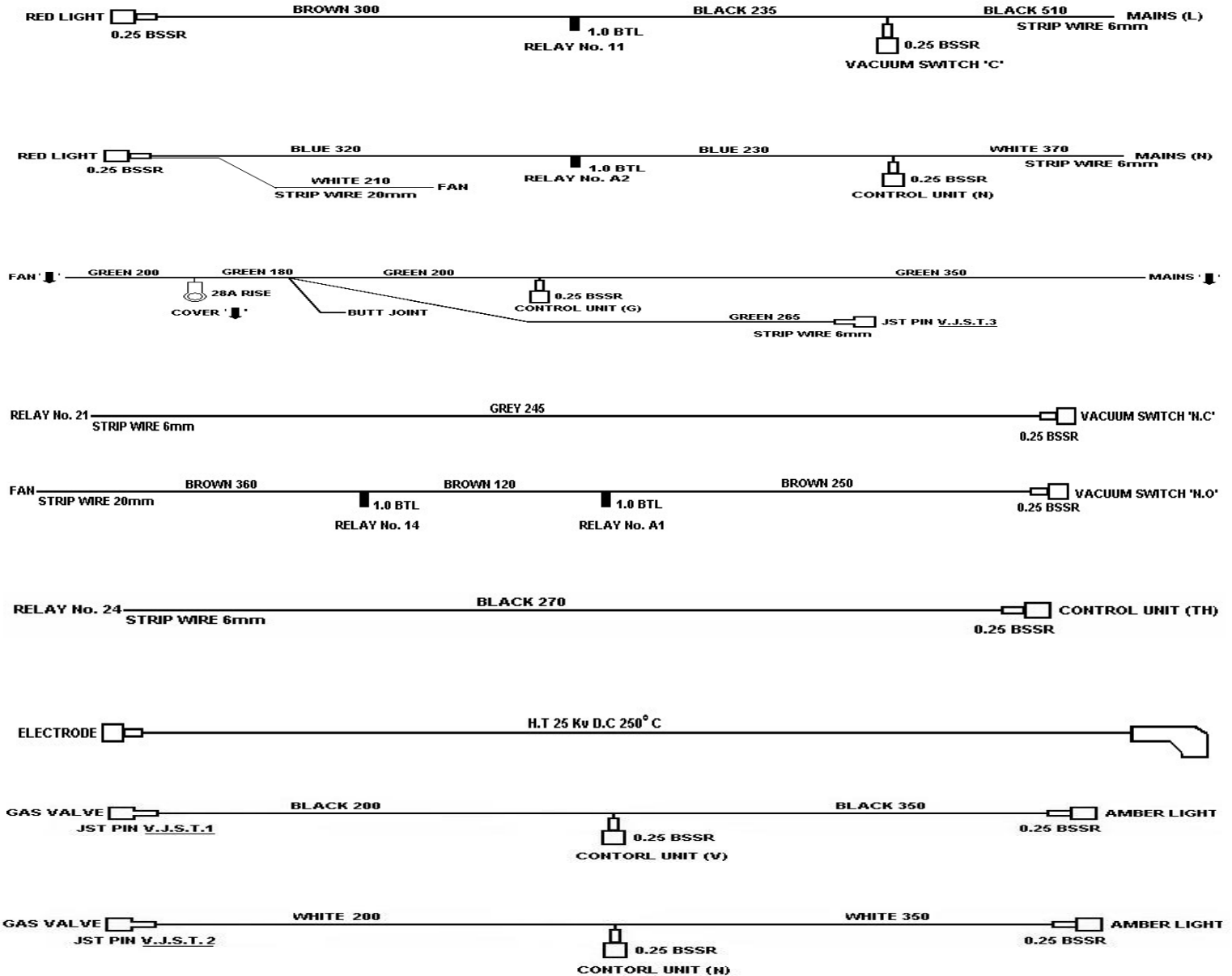

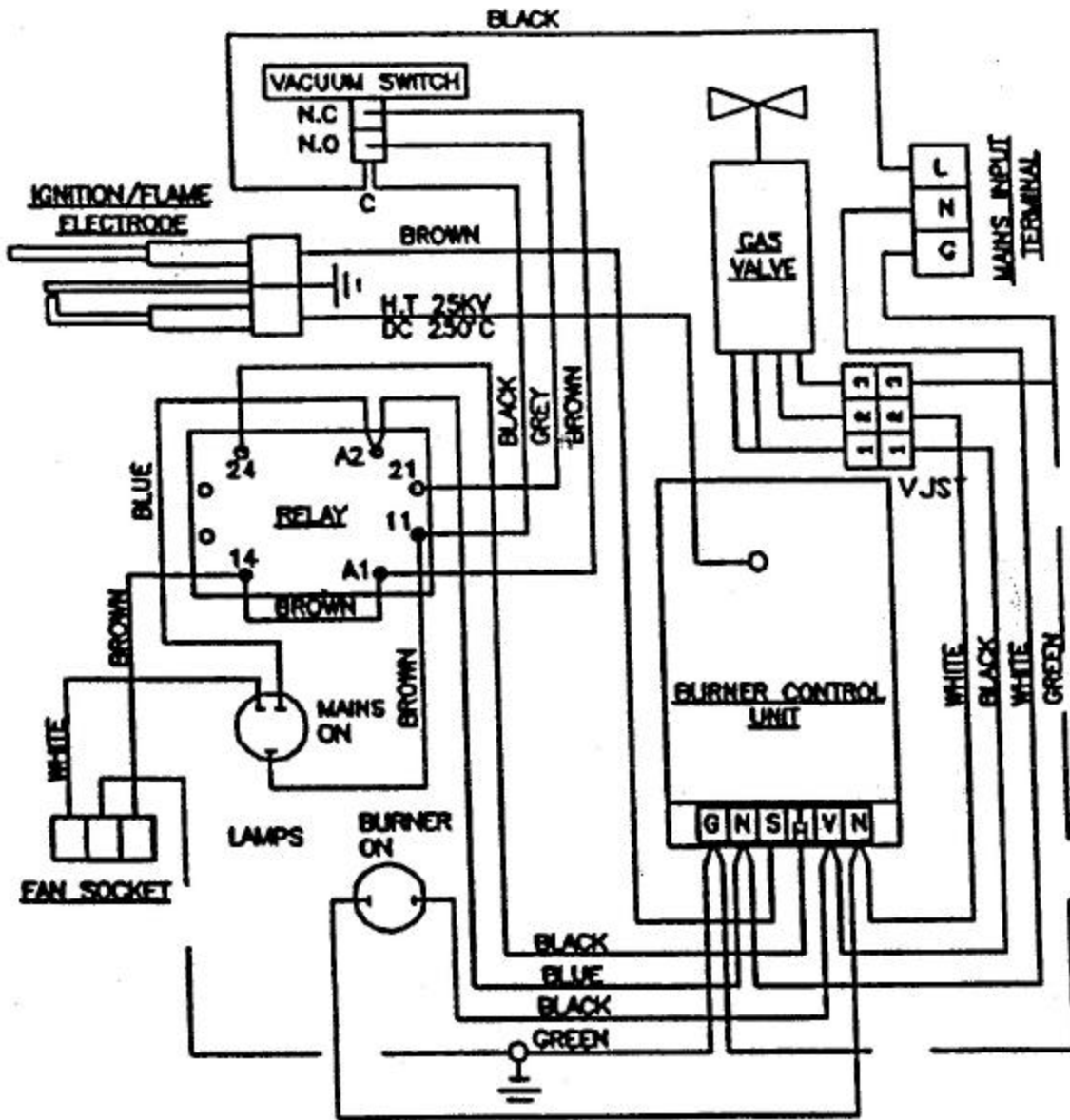

INTERNAL ELECTRICAL CIRCUIT 110V, 60HZ

ORANGE RELAY

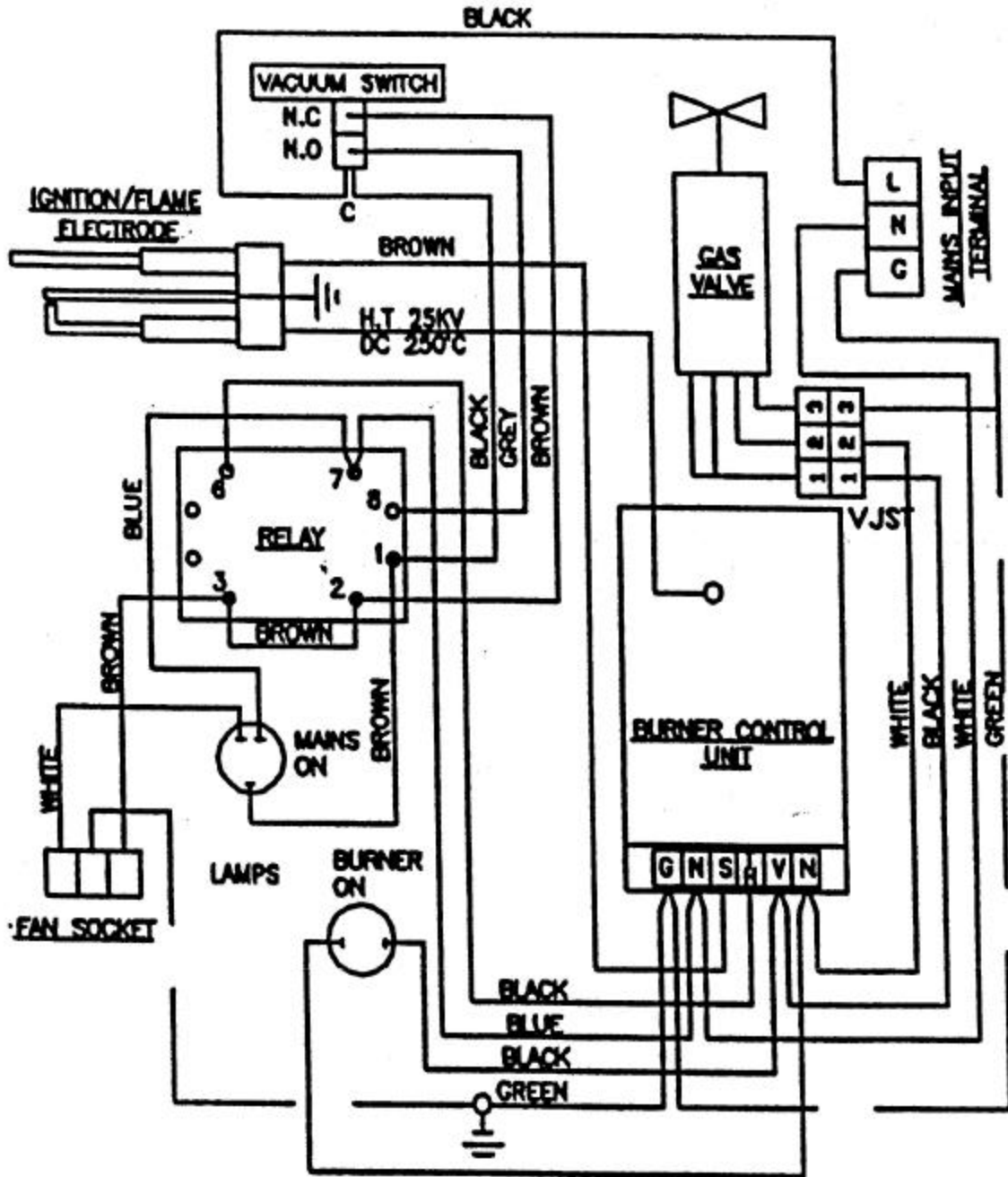

INTERNAL ELECTRICAL CIRCUIT 110V. 60HZ

BLACK (ICE CUBE) RELAY
CURRENT PRODUCTION

Wiring Schematic

(Part #: S-0500A)

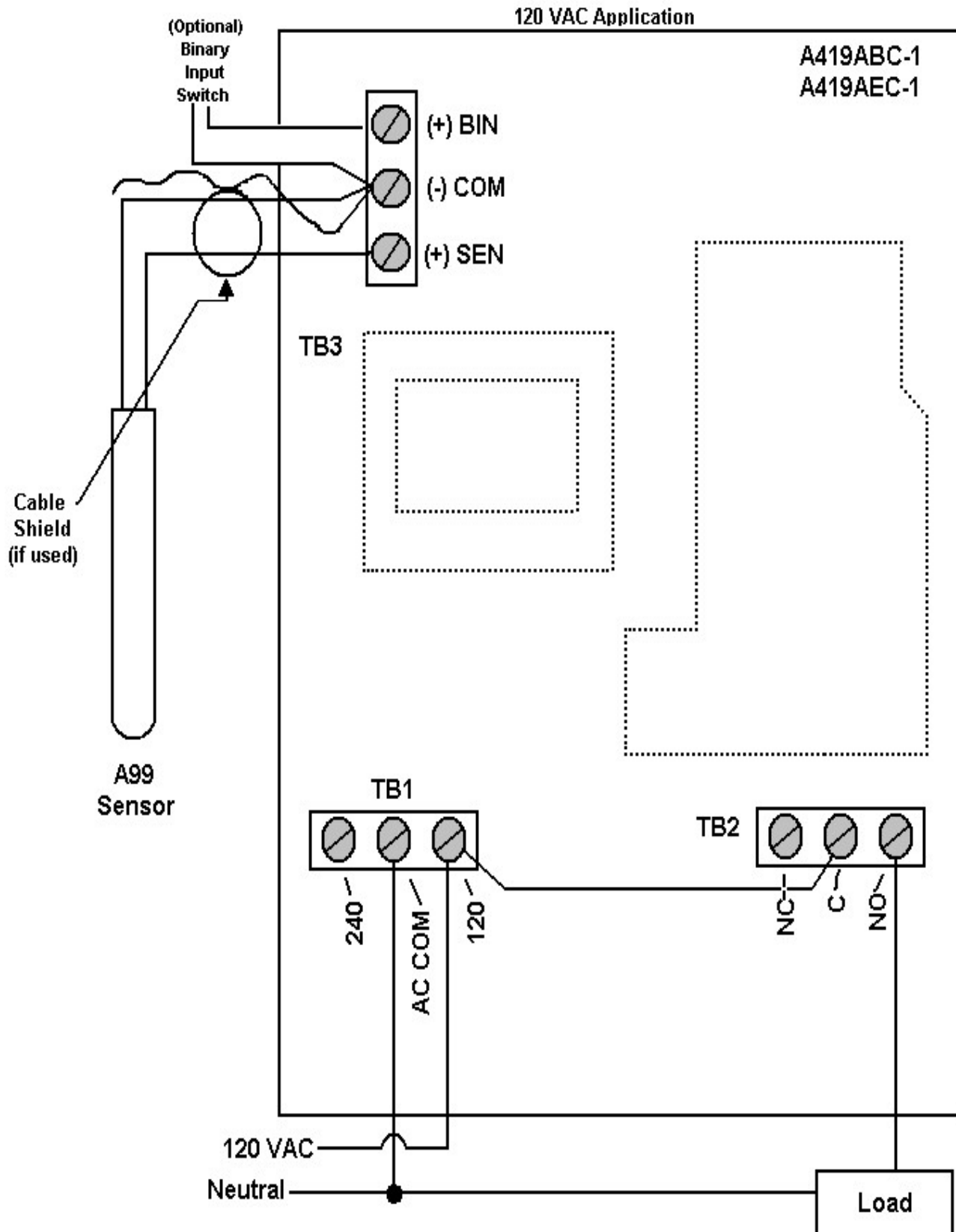

3" Ultimate Products Gas Infrared Heater - 40,000 - 75,000 btu Model "S20"

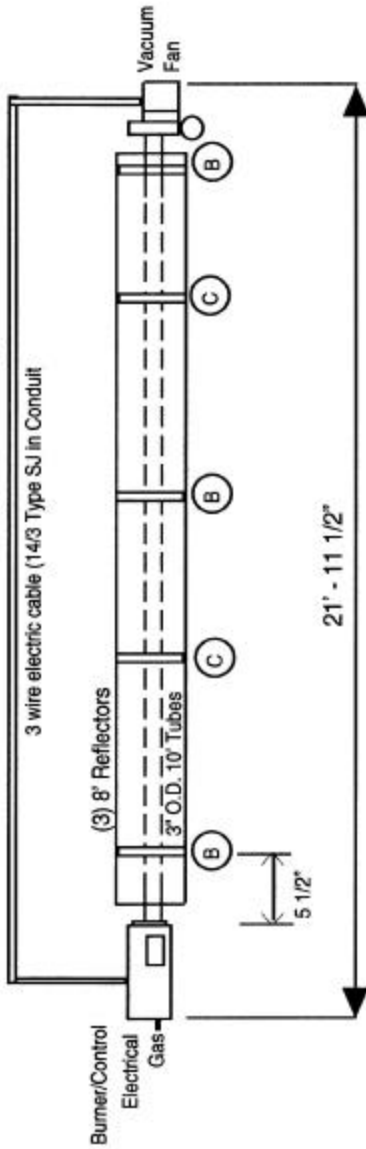

(C) Reflector Support Bracket : Bolt one end of each reflector to "C" Bracket **(B)** Bracket used for Suspension

BRACKET DETAIL

3" Straight Tube "C" Bracket Profile

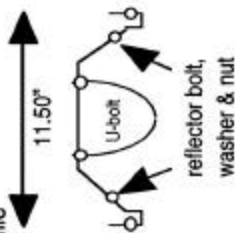

3" Straight Tube "B" Bracket Profile

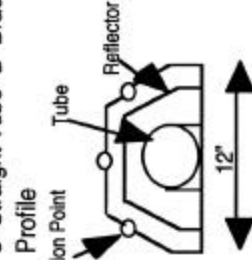

BURNER INSTALLATION DETAIL

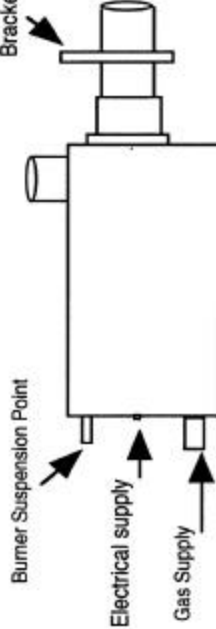

Lift From Bottom, Back of Burner While Tightening Allen Screws To Assure Burner Level, Attach Hanger Chain To Burner Suspension Point To Maintain Level and Provide Additional Support

All Tubing is color coded on the end to identify its composition

Red Stainless Steel
Yellow Aluminized Steel
Blue Mild Steel

Gas Supply Connection.....	1/2" NPT male	Minimum	
Gas supply pressure (inches w.c.)	Maximum	6.5	
Natural Gas.....	10.0		
L.P. Gas.....	14.0	11.0	
Electrical Supply.....	120V, single phase, 60Hz		
Current Rating.....	1.2A max. (Burner 0.3A; Fan 0.9A)		
Ignition.....	Electronic program start-up with spark ignition		

Model Number	BTH/HR	OPERATING GAS PRESSURE	
		Natural Gas	LP Gas
SGX/SA/CW/ER/AL/SC12S20	40,000	1.9" wc	6.7" wc
SGX/SA/CW/ER/AL/SC15S20	50,000	3.0" wc	10.5" wc
SGX/SA/CW/ER/AL/SC18S20	60,000	2.4" wc	6.7" wc
SGX/SA/CW/ER/AL/SC22S20	75,000	3.8" wc	10.5" wc

SERIES	COMBUSTION TUBE	REMAINING TUBE	REFLECTORS
SGX	Stainless Steel	Stainless Steel	Stainless Steel
SA	Stainless Steel	Stainless Steel	Aluminum
CW	Aluminized Steel	Aluminized Steel	Stainless Steel
ER	Aluminized Steel	Mild Steel	Stainless Steel
AL	Aluminized Steel	Aluminized Steel	Aluminum
SC	Aluminized Steel	Mild Steel	Aluminum

3" Ultimate Products Gas Infrared Heater- 40,000 - 75,000 btu Model "S25"

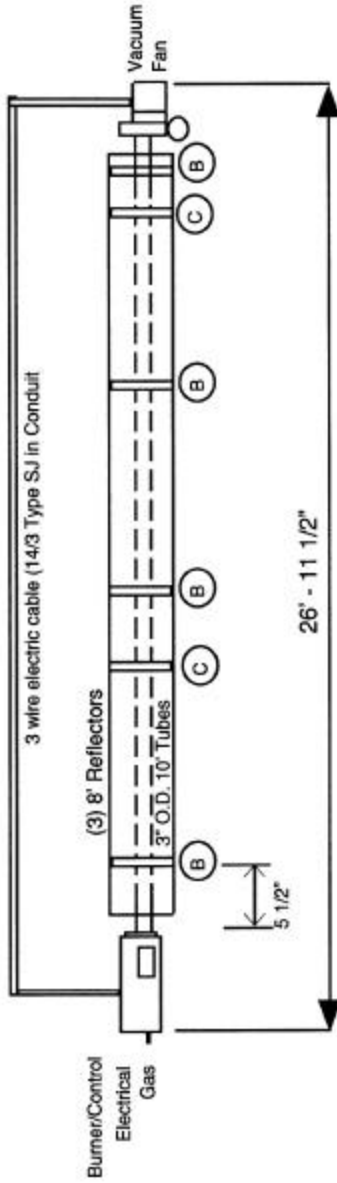

Ⓒ Reflector Support Bracket : Bolt one end of each reflector to "C" Bracket Ⓑ Bracket used for Suspension

BRACKET DETAIL

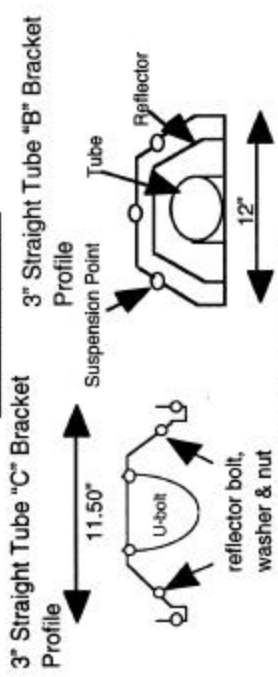

BURNER INSTALLATION DETAIL

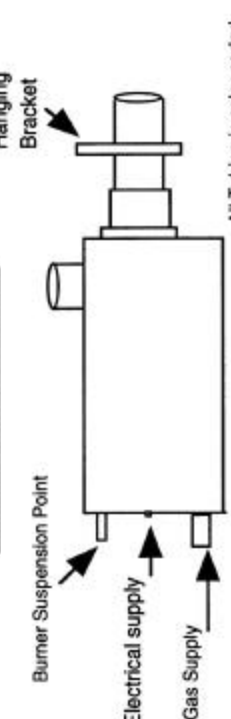

Lift From Bottom, Back of Burner While Tightening Allen Screws To Assure Burner Level, Attach Hanger Chain To Burner Suspension Point To Maintain Level and Provide Additional Support

Gas Supply Connection.....1/2" NPT male	Minimum
Gas supply pressure (inches w.c.)	Maximum 6.5
Natural Gas.....10.0	
L.P.Gas.....14.0	11.0
Electrical Supply.....120V, single phase, 60Hz	
Current Rating.....1.2A max. (Burner 0.3A; Fan 0.9A)	
Ignition.....Electronic program start-up with spark ignition	

Model Number	BTH/HR	OPERATING GAS PRESSURE	
		Natural Gas	LP Gas
SGX/SA/CW/ER/AL/SC12S25	40,000	1.9" wc	6.7" wc
SGX/SA/CW/ER/AL/SC15S25	50,000	3.0" wc	10.5" wc
SGX/SA/CW/ER/AL/SC18S25	60,000	2.4" wc	6.7" wc
SGX/SA/CW/ER/AL/SC22S25	75,000	3.8" wc	10.5" wc

SERIES	COMBUSTION TUBE	REMAINING TUBE	REFLECTORS
SGX	Stainless Steel	Stainless Steel	Stainless Steel
SA	Stainless Steel	Stainless Steel	Aluminum
CW	Aluminized Steel	Aluminized Steel	Stainless Steel
ER	Aluminized Steel	Mild Steel	Stainless Steel
AL	Aluminized Steel	Aluminized Steel	Aluminum
SC	Aluminized Steel	Mild Steel	Aluminum

3" Ultimate Products Gas Infrared Heater- 40,000 - 75,000 btu Model "S30"

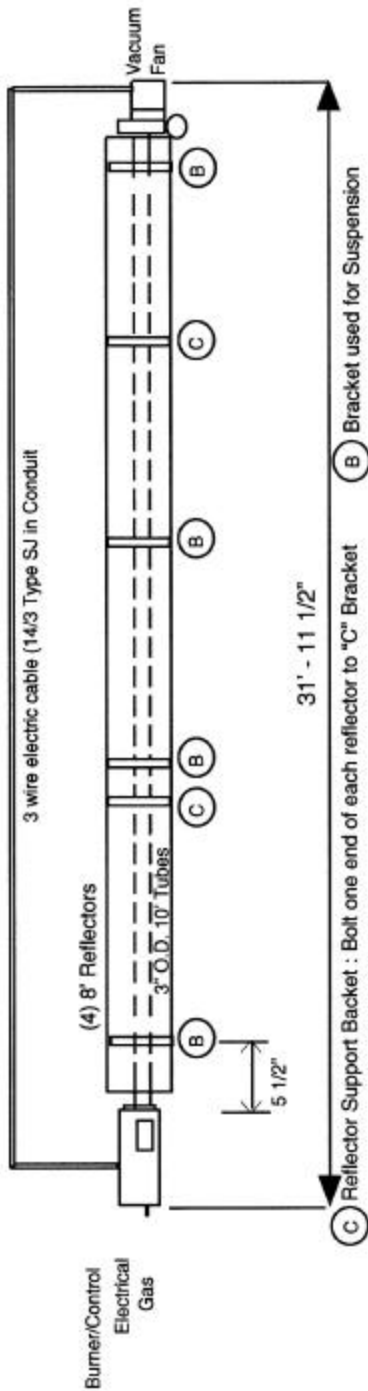

C Reflector Support Bracket : Bolt one end of each reflector to "C" Bracket **B** Bracket used for Suspension

BRACKET DETAIL

3" Straight Tube "C" Bracket Profile

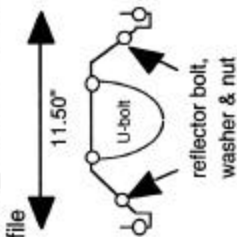

3" Straight Tube "B" Bracket Profile

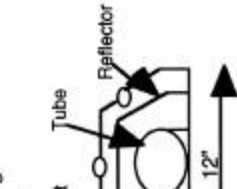

BURNER INSTALLATION DETAIL

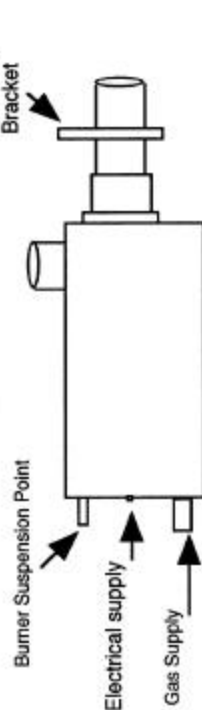

Lift From Bottom, Back of Burner While Tightening Allen Screws To Assure Burner Level, Attach Hanger Chain To Burner Suspension Point To Maintain Level and Provide Additional Support

All Tubing is color coded on the end to identify its composition

- Red Stainless Steel
- Yellow Aluminized Steel
- Blue Mild Steel

Gas Supply Connection.....1/2" NPT male	Minimum	
Gas supply pressure (inches w.c.)	Maximum	6.5
Natural Gas.....	10.0	
L.P. Gas.....	14.0	
Electrical Supply.....120V, single phase, 60Hz		
Current Rating.....1.2A max. (Burner 0.3A; Fan 0.9A)		
Ignition.....Electronic program start-up with spark ignition		
Model Number	BTH/HR	

Model Number	BTH/HR	OPERATING GAS PRESSURE	
		Natural Gas	LP Gas
SGX/SA/CW/ER/AL/SC12S30	40,000	1.9" wc	6.7" wc
SGX/SA/CW/ER/AL/SC15S30	50,000	3.0" wc	10.5" wc
SGX/SA/CW/ER/AL/SC18S30	60,000	2.4" wc	6.7" wc
SGX/SA/CW/ER/AL/SC22S30	75,000	3.8" wc	10.5" wc

SERIES	COMBUSTION TUBE	REMAINING TUBE	REFLECTORS
SGX	Stainless Steel	Stainless Steel	Stainless Steel
SA	Stainless Steel	Stainless Steel	Aluminum
CW	Aluminized Steel	Aluminized Steel	Stainless Steel
ER	Aluminized Steel	Mild Steel	Stainless Steel
AL	Aluminized Steel	Aluminized Steel	Aluminum
SC	Aluminized Steel	Mild Steel	Aluminum

3" Ultimate Products Gas Infrared Heater - 40,000 - 75,000 btu Model "S35"

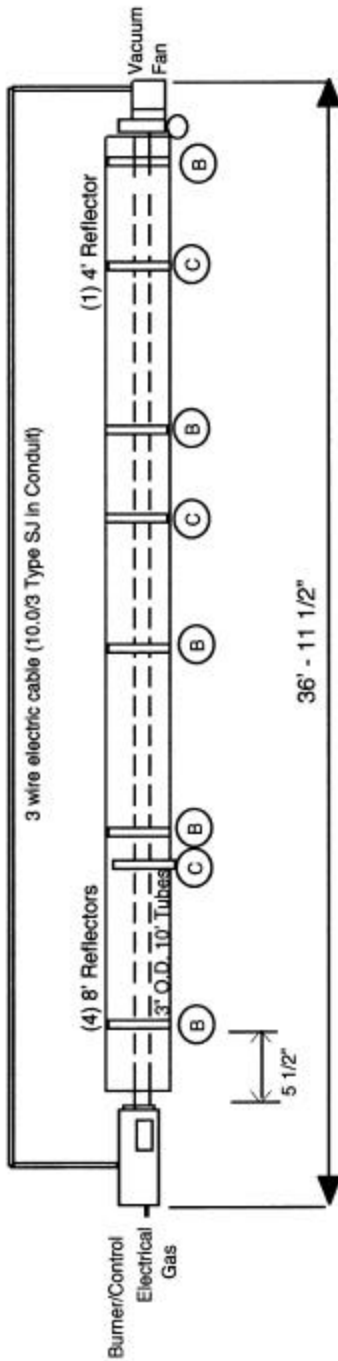

Ⓒ Reflector Support Bracket : Bolt one end of each reflector to "C" Bracket Ⓑ Bracket used for Suspension

BRACKET DETAIL

3" Straight Tube "C" Bracket Profile 3" Straight Tube "B" Bracket Profile

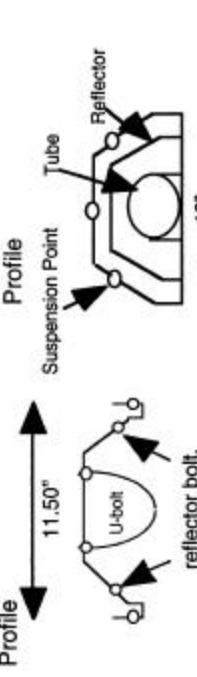

BURNER INSTALLATION DETAIL

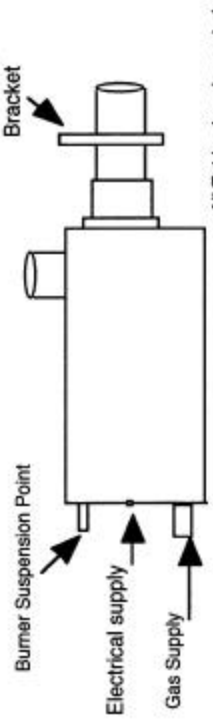

Lift From Bottom, Back of Burner While Tightening Allen Screws To Assure Burner Level, Attach Hanger Chain To Burner Suspension Point To Maintain Level and Provide Additional Support

Gas Supply Connection.....1/2" NPT male	Minimum	
Gas supply pressure (inches w.c.)	Maximum	6.5
Natural Gas.....10.0		
L.P. Gas.....14.0		11.0
Electrical Supply.....120V, single phase, 60Hz		
Current Rating.....1.2A max. (Burner 0.3A; Fan 0.9A)		
Ignition.....Electronic program start-up with spark ignition		

Model Number	BTH/HR	OPERATING GAS PRESSURE	
		Natural Gas	LP Gas
SGX/SA/CW/ER/AL/SC12S35	40,000	1.9" wc	6.7" wc
SGX/SA/CW/ER/AL/SC15S35	50,000	3.0" wc	10.5" wc
SGX/SA/CW/ER/AL/SC18S35	60,000	2.4" wc	6.7" wc
SGX/SA/CW/ER/AL/SC22S35	75,000	3.8" wc	10.5" wc

SERIES	COMBUSTION TUBE	REMAINING TUBE	REFLECTORS
SGX	Stainless Steel	Stainless Steel	Stainless Steel
SA	Stainless Steel	Stainless Steel	Aluminum
CW	Aluminized Steel	Aluminized Steel	Stainless Steel
ER	Aluminized Steel	Mild Steel	Stainless Steel
AL	Aluminized Steel	Aluminized Steel	Aluminum
SC	Aluminized Steel	Mild Steel	Aluminum

3" Ultimate Products Gas Infrared Heater- 40,000 - 75,000 btu Model "S40"

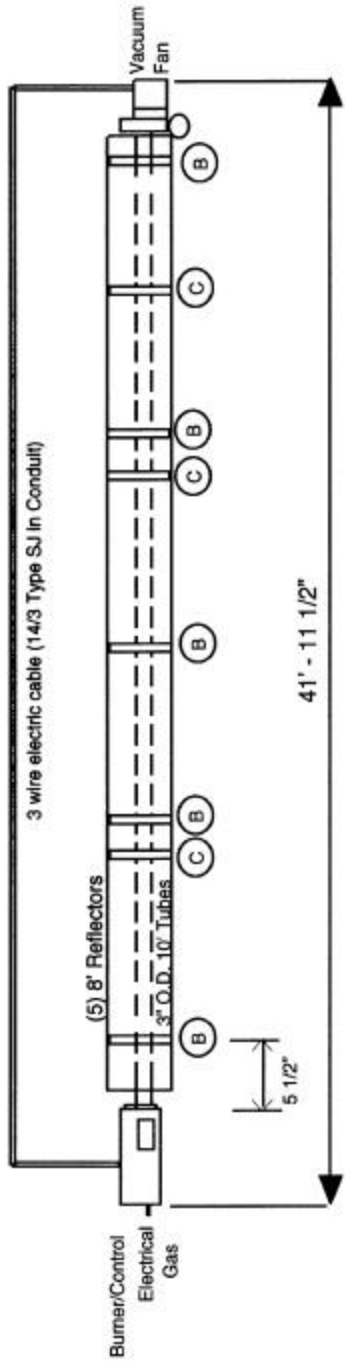

(C) Reflector Support Bracket : Bolt one end of each reflector to "C" Bracket **(B)** Bracket used for Suspension

BRACKET DETAIL

3" Straight Tube "C" Bracket Profile

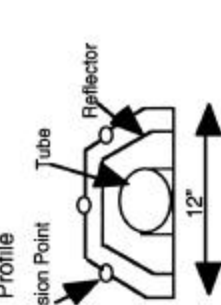
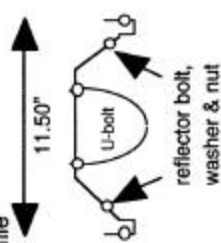

BURNER INSTALLATION DETAIL

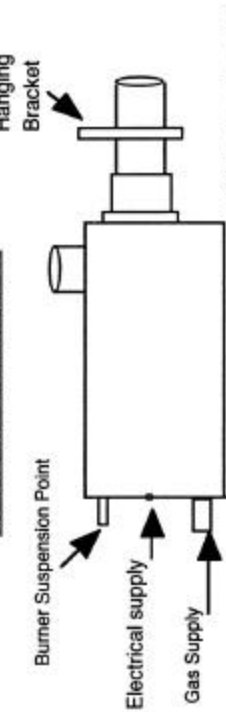

Lift From Bottom, Back of Burner While Tightening Allen Screws To Assure Burner Level, Attach Hanger Chain To Burner Suspension Point To Maintain Level and Provide Additional Support

All Tubing is color coded on the end to identify its composition

Red Stainless Steel
Yellow Aluminized Steel
Blue Mild Steel

Gas Supply Connection.....1/2" NPT male	Minimum
Gas supply pressure (inches w.c.)	Maximum 6.5
Natural Gas.....10.0	
L.P. Gas.....14.0	
Electrical Supply.....120V, single phase, 60Hz	
Current Rating.....1.2A max. (Burner 0.3A; Fan 0.9A)	
Ignition.....Electronic program start-up with spark ignition	

Model Number	BTH/HR	OPERATING GAS PRESSURE	
		Natural Gas	LP Gas
SGX/SA/CW/ER/AL/SC12S40	40,000	1.9" wc	6.7" wc
SGX/SA/CW/ER/AL/SC15S40	50,000	3.0" wc	10.5" wc
SGX/SA/CW/ER/AL/SC18S40	60,000	2.4" wc	6" wc
SGX/SA/CW/ER/AL/SC22S40	75,000	3.8" wc	10.5" wc

SERIES	COMBUSTION TUBE	REMAINING TUBE	REFLECTORS
SGX	Stainless Steel	Stainless Steel	Stainless Steel
SA	Stainless Steel	Stainless Steel	Aluminum
CW	Aluminized Steel	Aluminized Steel	Stainless Steel
ER	Aluminized Steel	Mild Steel	Stainless Steel
AL	Aluminized Steel	Aluminized Steel	Aluminum
SC	Aluminized Steel	Mild Steel	Aluminum

3" Ultimate Products Gas Infrared Heater- 40,000 - 75,000 btu Model "S45"

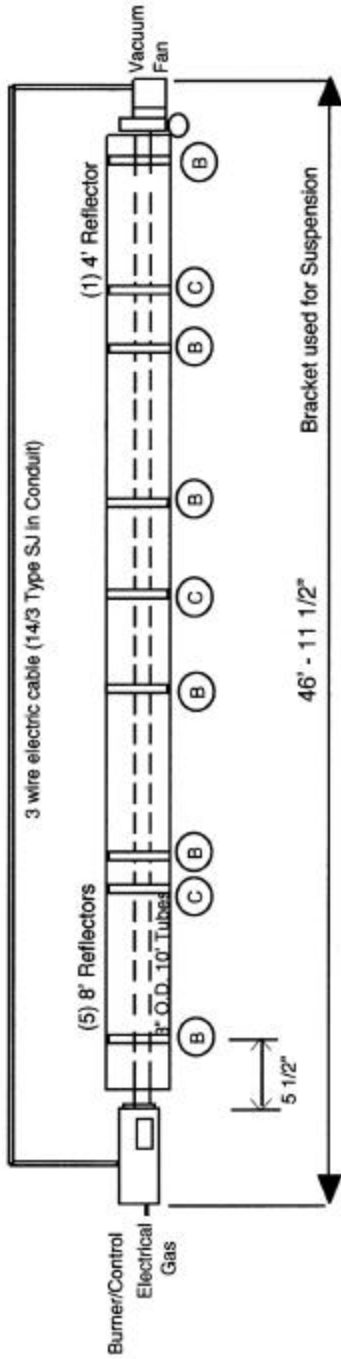

(C) Reflector Support Bracket : Bolt one end of each reflector to "C" Bracket (B) Bracket used for Suspension

BRACKET DETAIL

3" Straight Tube "C" Bracket Profile

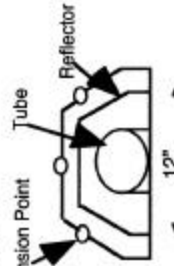
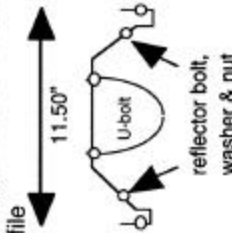

BURNER INSTALLATION DETAIL

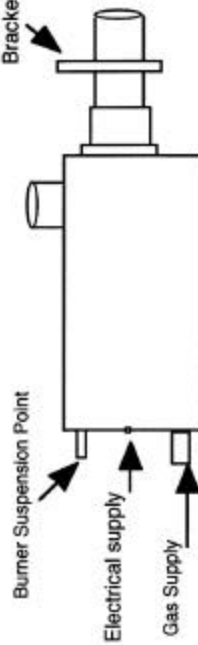

Lift From Bottom, Back of Burner While Tightening Allen Screws To Assure Burner Level, Attach Hanger Chain To Burner Suspension Point To Maintain Level and Provide Additional Support

All Tubing is color coded on the end to identify its composition

Red Stainless Steel
Yellow Aluminized Steel
Blue Mild Steel

Gas Supply Connection.....1/2" NPT male	Minimum
Gas supply pressure (inches w.c.)	Maximum 6.5
Natural Gas.....	10.0
L.P.Gas.....	14.0
Electrical Supply.....120V, single phase, 60Hz	
Current Rating.....1.2A max. (Burner 0.3A; Fan 0.9A)	
Ignition.....Electronic program start-up with spark ignition	

Model Number	BTH/HR	OPERATING GAS PRESSURE	
		Natural Gas	LP Gas
SGX/SA/CW/ER/AL/SC12S45	40,000	1.9" wc	6.7" wc
SGX/SA/CW/ER/AL/SC15S45	50,000	3.0" wc	10.5" wc
SGX/SA/CW/ER/AL/SC18S45	60,000	2.4" wc	6.7" wc
SGX/SA/CW/ER/AL/SC22S45	75,000	3.8" wc	10.5" wc

SERIES	COMBUSTION TUBE	REMAINING TUBE	REFLECTORS
SGX	Stainless Steel	Stainless Steel	Stainless Steel
SA	Stainless Steel	Stainless Steel	Aluminum
CW	Aluminized Steel	Aluminized Steel	Stainless Steel
ER	Aluminized Steel	Mild Steel	Stainless Steel
AL	Aluminized Steel	Aluminized Steel	Aluminum
SC	Aluminized Steel	Mild Steel	Aluminum

4" Ultimate Products Gas Infrared Heater - 100,000btu - 130,000btu Model "S30"

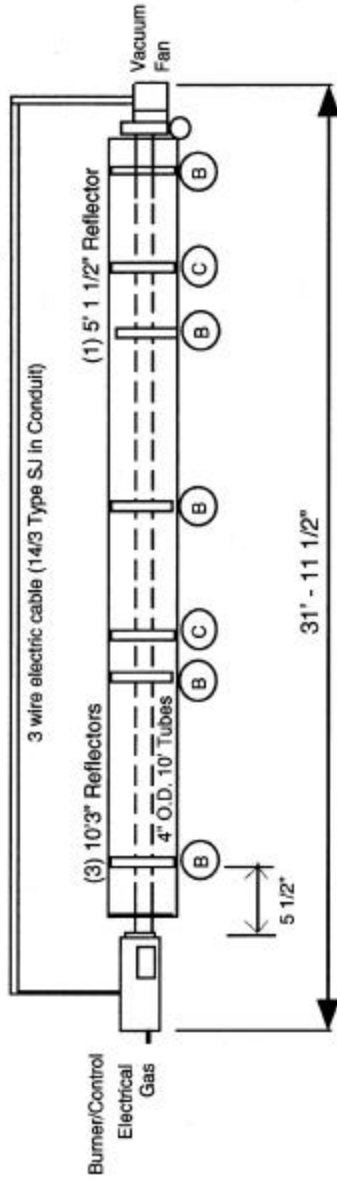

(C) Reflector Support Bracket : Bolt one end of each reflector to "C" Bracket
 (B) Bracket used for Suspension

BRACKET DETAIL

4" Straight "C" Bracket Profile

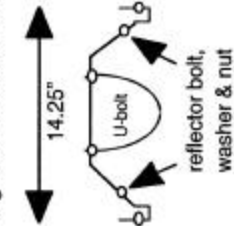

4" Straight Tube "B" Bracket Profile

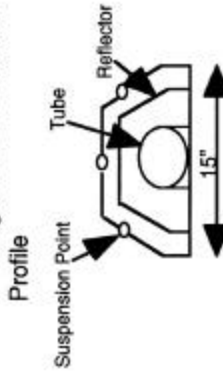

Gas Supply Connection.....	1/2" NPT male
Gas supply pressure (inches w.c.)	Minimum 6.5 Maximum 10.0
Natural Gas.....	10.0
L.P. Gas.....	14.0
Electrical Supply.....	120V, single phase, 60Hz
Current Rating.....	1.2A max. (Burner 0.3A; Fan 0.9A)
Ignition.....	Electronic program start-up with spark ignition

BURNER INSTALLATION DETAIL

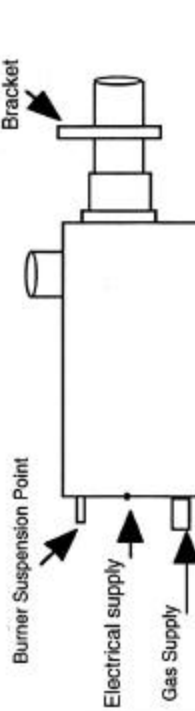

Lift From Bottom, Back of Burner While Tightening Allen Screws To Assure Burner Level, Attach Hanger Chain To Burner Suspension Point To Maintain Level and Provide Additional Support

All Tubing is color coded on the end to identify its composition

- Red Stainless Steel
- Yellow Aluminized Steel
- Blue Mild Steel

Model Number	BTH/HR	OPERATING GAS PRESSURE	
		Natural Gas	LP Gas
SGX/SA/CW/ER/AL/SC29S35	100,000	4.9" wc	10" wc
SGX/SA/CW/ER/AL/SC38S35	130,000	4.9" wc	10" wc

SERIES	COMBUSTION TUBE	REMAINING TUBE	REFLECTORS
SGX	Stainless Steel	Stainless Steel	Stainless Steel
SA	Stainless Steel	Stainless Steel	Aluminum
CW	Aluminized Steel	Aluminized Steel	Stainless Steel
ER	Aluminized Steel	Mild Steel	Stainless Steel
AL	Aluminized Steel	Aluminized Steel	Aluminum
SC	Aluminized Steel	Mild Steel	Aluminum

4" Ultimate Products Gas Infrared Heater - 100,000btu - 130,000btu Model "S35"

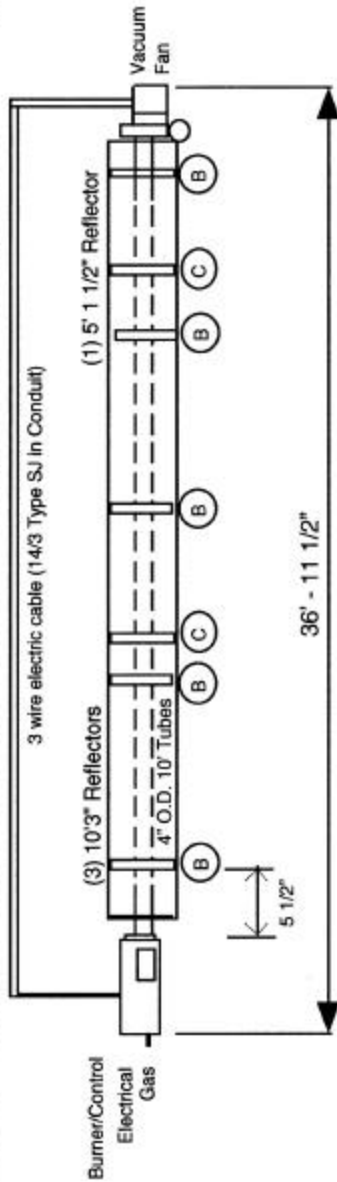

(C) Reflector Support Bracket : Bolt one end of each reflector to "C" Bracket (B) Bracket used for Suspension

BRACKET DETAIL

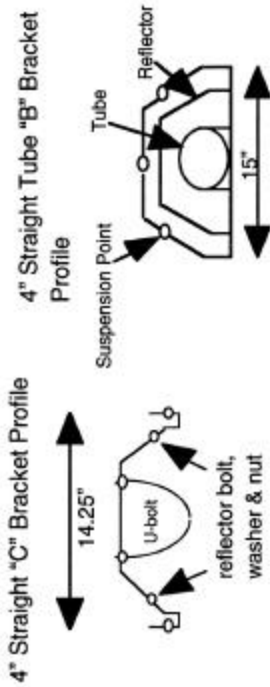

Gas Supply Connection.....1/2" NPT male	Minimum
Gas supply pressure (inches w.c.)	Maximum
Natural Gas.....	6.5
L.P. Gas.....	11.0
Electrical Supply.....120V, single phase, 60Hz	14.0
Current Rating.....	14.0
Ignition.....Electronic program start-up with spark ignition	

Model Number	BTH/HR	OPERATING GAS PRESSURE	
		Natural Gas	LP Gas
SGX/SA/CW/ER/AL/SC29S35	100,000	4.9" WC	10" WC
SGX/SA/CW/ER/AL/SC38S35	130,000	4.9" WC	10" WC

SERIES	COMBUSTION TUBE	REMAINING TUBE	REFLECTORS
SGX	Stainless Steel	Stainless Steel	Stainless Steel
SA	Stainless Steel	Stainless Steel	Aluminum
CW	Aluminized Steel	Aluminized Steel	Stainless Steel
ER	Aluminized Steel	Mild Steel	Stainless Steel
AL	Aluminized Steel	Aluminized Steel	Aluminum
SC	Aluminized Steel	Mild Steel	Aluminum

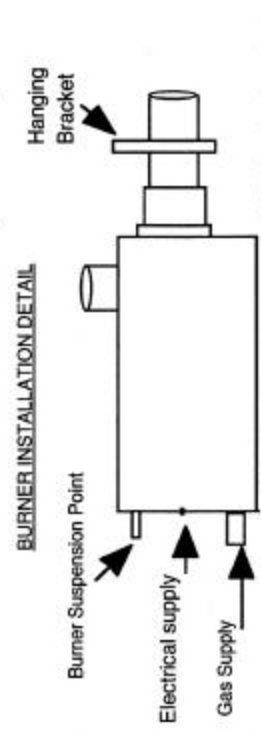

Lift From Bottom, Back of Burner While Tightening Allen Screws To Assure Burner Level, Attach Hanger Chain To Burner Suspension Point To Maintain Level and Provide Additional Support

4" Ultimate Products Gas Infrared Heater - 100,000btu - 150,000btu Model "S40"

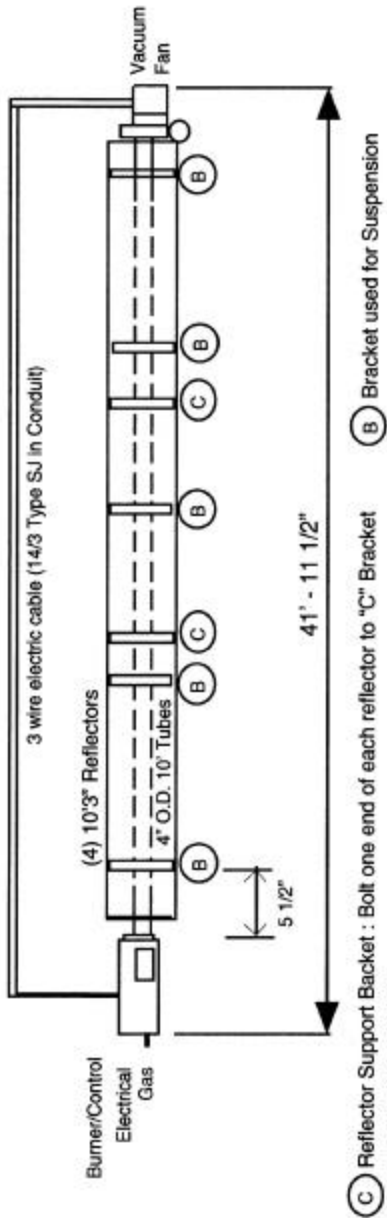

(C) Reflector Support Bracket : Bolt one end of each reflector to "C" Bracket
 (B) Bracket used for Suspension

4" Straight "C" Bracket Profile

4" Straight Tube "B" Bracket Profile

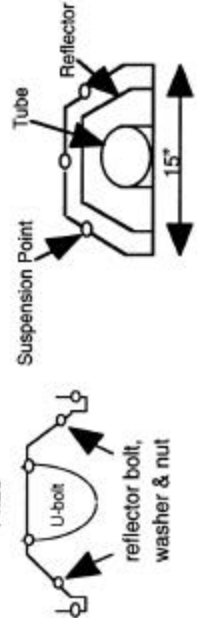

BURNER INSTALLATION DETAIL

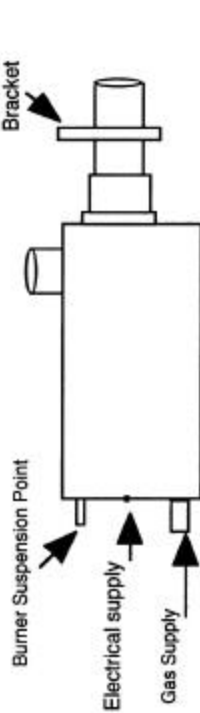

Lift From Bottom, Back of Burner While Tightening Allen Screws To Assure Burner Level, Attach Hanger Chain To Burner Suspension Point To Maintain Level and Provide Additional Support

All Tubing is color coded on the end to identify its composition

Red Stainless Steel
 Yellow Aluminized Steel
 Blue Mild Steel

Gas Supply Connection.....1/2" NPT male	Minimum
Gas supply pressure (inches w.c.) Maximum	6.5
Natural Gas.....14.0	11.0
L.P. Gas.....14.0	14.0
Electrical Supply.....120V, single phase, 60Hz	
Current Rating.....1.2A max. (Burner 0.3A; Fan 0.9A)	
Ignition.....Electronic program start-up with spark ignition	

Model Number	BTH/HR	OPERATING GAS PRESSURE	
		Natural Gas	LP Gas
SGX/SA/CW/ER/AL/SC29S40	100,000	4.9" WC	10" WC
SGX/SA/CW/ER/AL/SC36S40	130,000	4.9" WC	10" WC
SGX/SA/CW/ER/AL/SC44S40	150,000	4.6" WC	10" WC

SERIES	COMBUSTION TUBE	REMAINING TUBE	REFLECTORS
SGX	Stainless Steel	Stainless Steel	Stainless Steel
SA	Stainless Steel	Stainless Steel	Aluminum
CW	Aluminized Steel	Aluminized Steel	Stainless Steel
ER	Aluminized Steel	Mild Steel	Stainless Steel
AL	Aluminized Steel	Aluminized Steel	Aluminum
SC	Aluminized Steel	Mild Steel	Aluminum

4" Ultimate Products Gas Infrared Heater - 100,000btu - 150,000btu Model "S45"

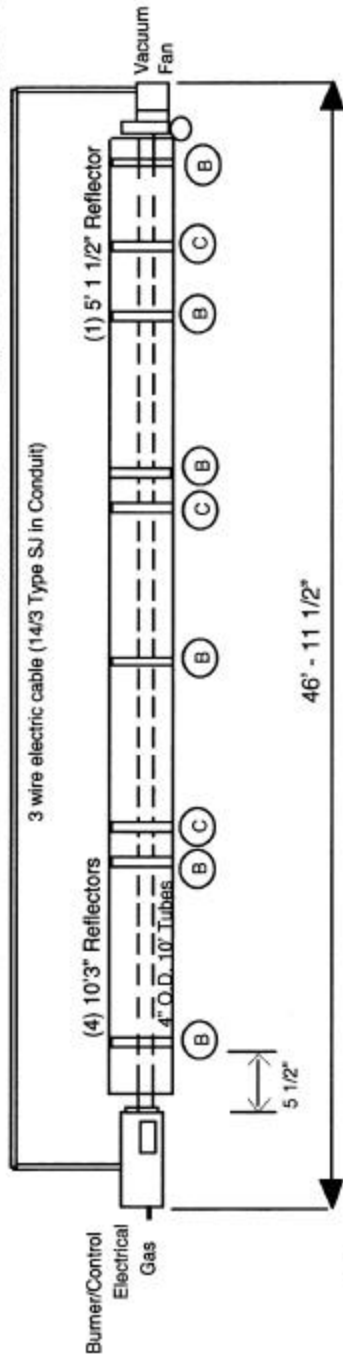

Ⓒ Reflector Support Bracket : Bolt one end of each reflector to "C" Bracket
 Ⓓ Bracket used for Suspension

BRACKET DETAIL

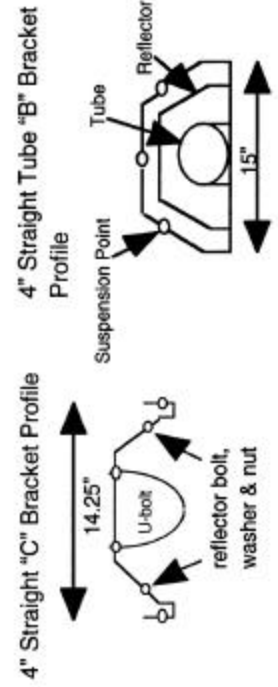

BURNER INSTALLATION DETAIL

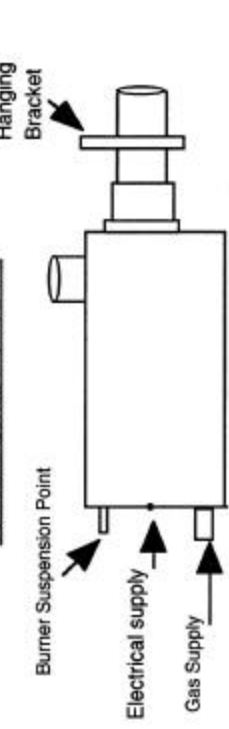

Lift From Bottom, Back of Burner While Tightening Allen Screws To Assure Burner Level, Attach Hanger Chain To Burner Suspension Point To Maintain Level and Provide Additional Support

All Tubing is color coded on the end to identify its composition
 Red Stainless Steel
 Yellow Aluminized Steel
 Blue Mild Steel

Gas Supply Connection.....1/2" NPT male	Minimum
Gas supply pressure (inches w.c.)	6.5
Natural Gas.....	10.0
L.P. Gas.....	14.0
Electrical Supply.....120V, single phase, 60Hz	
Current Rating.....	1.2A max. (Burner 0.3A; Fan 0.9A)
Ignition.....	Electronic program start-up with spark ignition

Model Number	BTH/HR	OPERATING GAS PRESSURE	
		Natural Gas	L.P. Gas
SGX/SA/CW/ERIAL/SC29S45	100,000	4.9" wc	10" wc
SGX/SA/CW/ERIAL/SC38S45	130,000	4.9" wc	10" wc
SGX/SA/CW/ERIAL/SC44S45	150,000	4.6" wc	10" wc

SERIES	COMBUSTION TUBE	REMAINING TUBE	REFLECTORS
SGX	Stainless Steel	Stainless Steel	Stainless Steel
SA	Stainless Steel	Stainless Steel	Aluminum
CW	Aluminized Steel	Aluminized Steel	Stainless Steel
ER	Aluminized Steel	Mild Steel	Stainless Steel
AL	Aluminized Steel	Aluminized Steel	Aluminum
SC	Aluminized Steel	Mild Steel	Aluminum

4" Ultimate Products Gas Infrared Heater - 100,000btu - 150,000btu Model "S50"

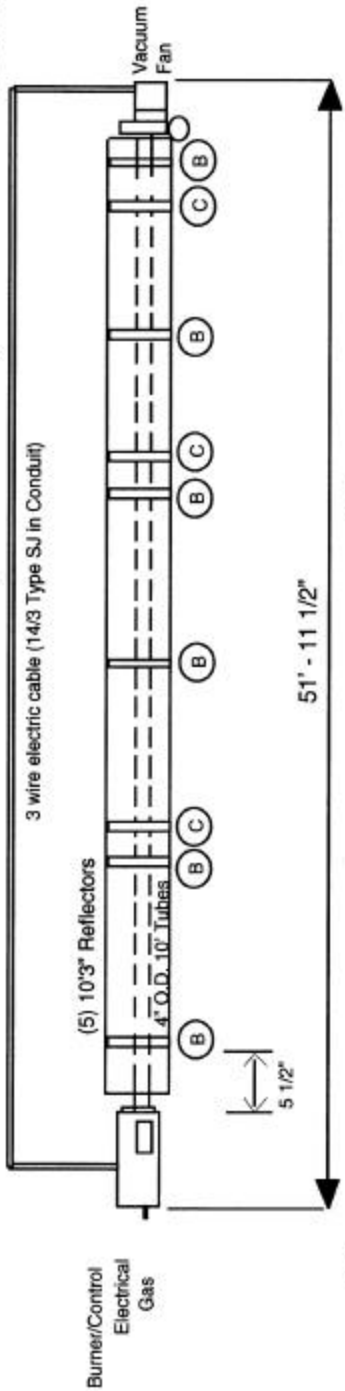

(C) Reflector Support Bracket : Bolt one end of each reflector to "C" Bracket
 (B) Bracket used for Suspension

BRACKET DETAIL

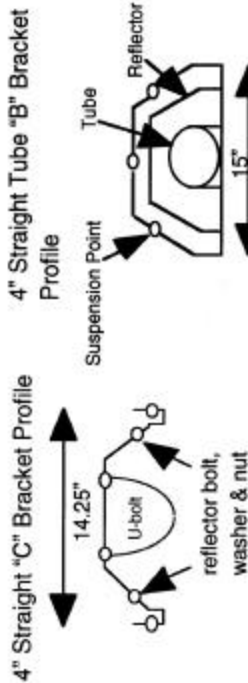

BURNER INSTALLATION DETAIL

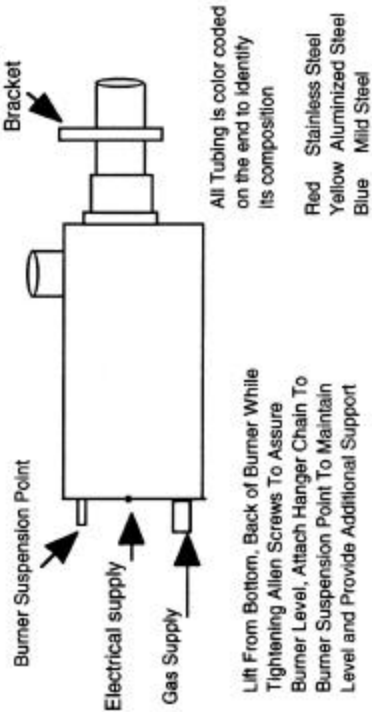

Gas Supply Connection.....	1/2" NPT male
Gas supply pressure (inches w.c.) - Minimum	6.5
Natural Gas.....	10.0
L.P. Gas.....	11.0
Electrical Supply.....	120V, single phase, 60Hz
Current Rating.....	1.2A max. (Burner 0.3A; Fan 0.9A)
Ignition.....	Electronic program start-up with spark ignition

Model Number	BTH/HR	OPERATING GAS PRESSURE	
		Natural Gas	LP Gas
SGX/SA/CW/ER/AL/SC29S50	100,000	4.9" WC	10" WC
SGX/SA/CW/ER/AL/SC38S50	130,000	4.9" WC	10" WC
SGX/SA/CW/ER/AL/SC44S50	150,000	4.6" WC	10" WC

SERIES	COMBUSTION TUBE	REMAINING TUBE	REFLECTORS
SGX	Stainless Steel	Stainless Steel	Stainless Steel
SA	Stainless Steel	Stainless Steel	Aluminum
CW	Aluminized Steel	Aluminized Steel	Stainless Steel
ER	Aluminized Steel	Mild Steel	Stainless Steel
AL	Aluminized Steel	Aluminized Steel	Aluminum
SC	Aluminized Steel	Mild Steel	Aluminum

4" Ultimate Products Gas Infrared Heater - 100,000btu - 150,000btu Model "S55"

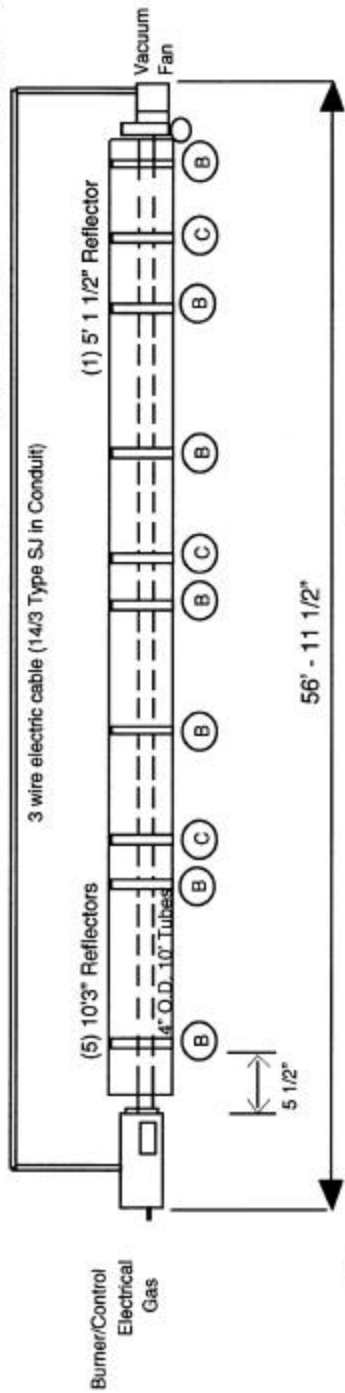

C Reflector Support Bracket : Bolt one end of each reflector to "C" Bracket
B Bracket used for Suspension

BRACKET DETAIL

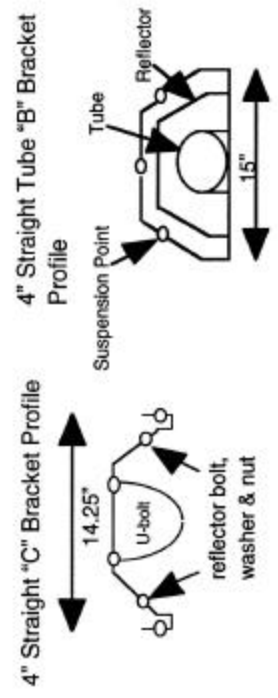

BURNER INSTALLATION DETAIL

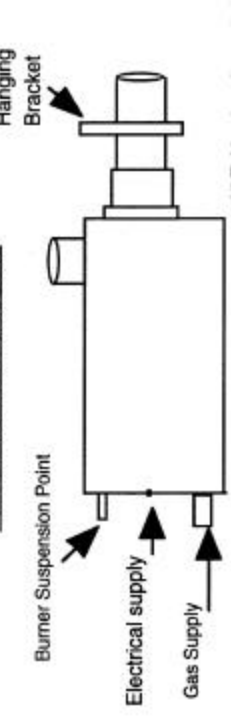

Lift From Bottom, Back of Burner While Tightening Allen Screws To Assure Burner Level, Attach Hanger Chain To Burner Suspension Point To Maintain Level and Provide Additional Support

All Tubing is color coded on the end to identify its composition
 Red Stainless Steel
 Yellow Aluminumized Steel
 Blue Mild Steel

Gas Supply Connection.....1/2" NPT male	Minimum	
Gas supply pressure (Inches w.c.)	Maximum	6.5
Natural Gas.....	10.0	
L.P. Gas.....	14.0	11.0
Electrical Supply.....	120V, single phase, 60Hz	
Current Rating.....	1.2A max. (Burner 0.3A; Fan 0.9A)	
Ignition.....	Electronic program start-up with spark ignition	

Model Number	BTH/HR	OPERATING GAS PRESSURE	
		Natural Gas	LP Gas
SGX/SA/CW/ER/AL/SC29S55	100,000	4.9" wc	10" wc
SGX/SA/CW/ER/AL/SC38S55	130,000	4.9" wc	10" wc
SGX/SA/CW/ER/AL/SC44S55	150,000	4.6" wc	10" wc

SERIES	COMBUSTION TUBE	REMAINING TUBE	REFLECTORS
SGX	Stainless Steel	Stainless Steel	Stainless Steel
SA	Stainless Steel	Stainless Steel	Aluminum
CW	Aluminumized Steel	Aluminumized Steel	Stainless Steel
ER	Aluminumized Steel	Mild Steel	Stainless Steel
AL	Aluminumized Steel	Aluminumized Steel	Aluminum
SC	Aluminumized Steel	Mild Steel	Aluminum



4" Ultimate Products Gas Infrared Heater - 100,000btu - 150,000btu Model "S60"

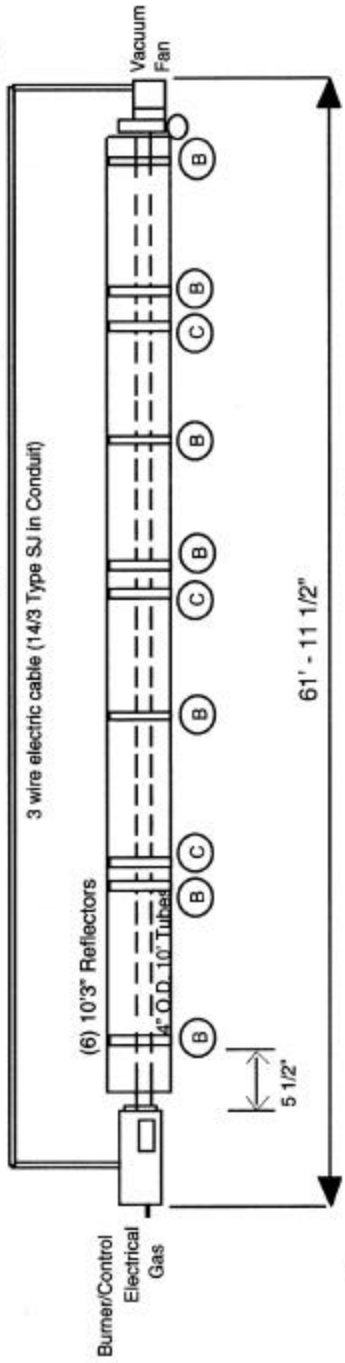

Ⓒ Reflector Support Bracket : Bolt one end of each reflector to "C" Bracket
 Ⓓ Bracket used for Suspension

BRACKET DETAIL

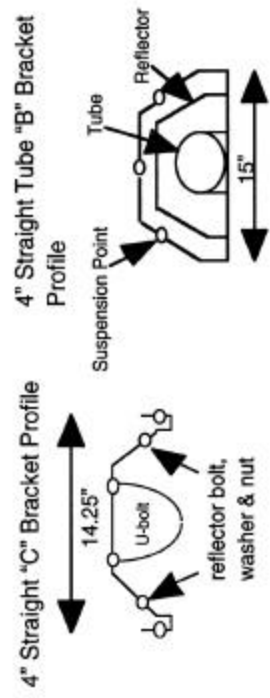

BURNER INSTALLATION DETAIL

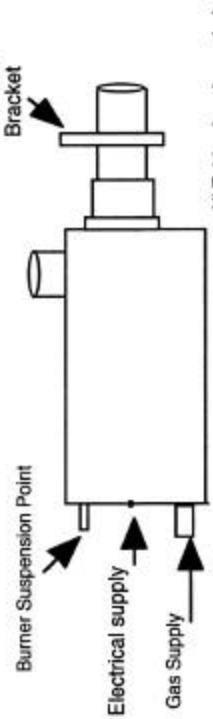

Lift From Bottom; Back of Burner While Tightening Allen Screws To Assure Burner Level; Attach Hanger Chain To Burner Suspension Point To Maintain Level and Provide Additional Support

All Tubing is color coded on the end to identify its composition
 Red Stainless Steel
 Yellow Aluminized Steel
 Blue Mild Steel

Gas Supply Connection.....1/2" NPT male	Minimum
Gas supply pressure (inches w.c.) Maximum	6.5
Natural Gas.....10.0	11.0
L.P.Gas.....14.0	
Electrical Supply.....120V, single phase, 60HZ	
Current Rating.....1.2A max. (Burner 0.3A; Fan 0.9A)	
Ignition.....Electronic program start-up with spark ignition	

Model Number	BTH/HR	OPERATING GAS PRESSURE	
		Natural Gas	LP Gas
SGX/SA/CW/ER/AL/SC29S60	100,000	4.9" wc	10" wc
SGX/SA/CW/ER/AL/SC38S60	130,000	4.9" wc	10" wc
SGX/SA/CW/ER/AL/SC44S60	150,000	4.6" wc	10" wc

SERIES	COMBUSTION TUBE	REMAINING TUBE	REFLECTORS
SGX	Stainless Steel	Stainless Steel	Stainless Steel
SA	Stainless Steel	Stainless Steel	Aluminum
CW	Aluminized Steel	Aluminized Steel	Stainless Steel
ER	Aluminized Steel	Mild Steel	Stainless Steel
AL	Aluminized Steel	Aluminized Steel	Aluminum
SC	Aluminized Steel	Mild Steel	Aluminum

4" Ultimate Products Gas Infrared Heater - 100,000btu - 150,000btu Model "S65"

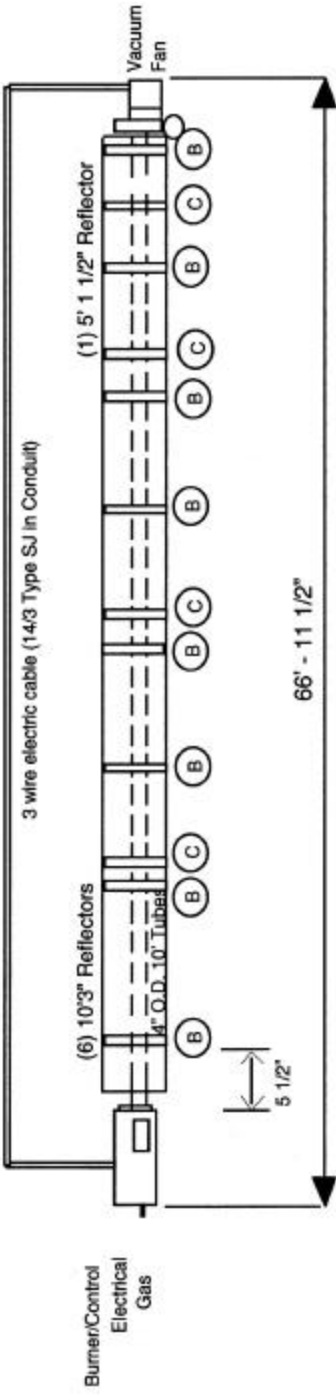

(C) Reflector Support Bracket : Bolt one end of each reflector to "C" Bracket
(B) Bracket used for Suspension

BRACKET DETAIL

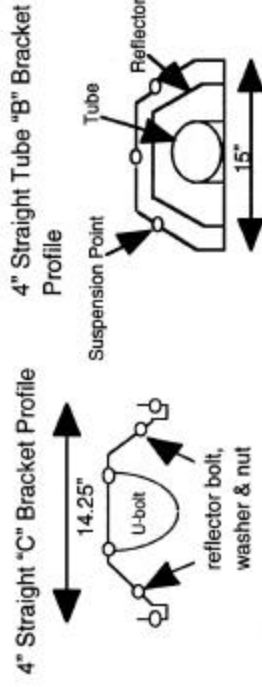

BURNER INSTALLATION DETAIL

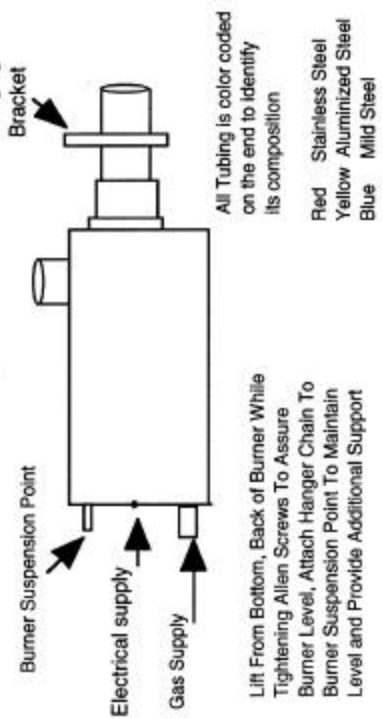

Gas Supply Connection.....	1/2" NPT male
Gas supply pressure (inches w.c.) - Minimum	6.5
Natural Gas.....	10.0
L.P. Gas.....	11.0
Electrical Supply.....	120V, single phase, 60Hz
Current Rating.....	1.2A max. (Burner 0.3A; Fan 0.9A)
Ignition.....	Electronic program start-up with spark ignition

Model Number	BTH/HR	OPERATING GAS PRESSURE	
		Natural Gas	LP Gas
SGX/SACW/ER/AL/SC29S65	100,000	4.9" wc	10" wc
SGX/SACW/ER/AL/SC38S65	130,000	4.9" wc	10" wc
SGX/SACW/ER/AL/SC44S65	150,000	4.6" wc	10" wc

SERIES	COMBUSTION TUBE	REMAINING TUBE	REFLECTORS
SGX	Stainless Steel	Stainless Steel	Stainless Steel
SA	Stainless Steel	Stainless Steel	Aluminum
CW	Aluminized Steel	Aluminized Steel	Stainless Steel
ER	Aluminized Steel	Mild Steel	Stainless Steel
AL	Aluminized Steel	Aluminized Steel	Aluminum
SC	Aluminized Steel	Mild Steel	Aluminum

3" Ultimate Products Gas Infrared Heater- 40,000 - 75,000 btu Model "U20"

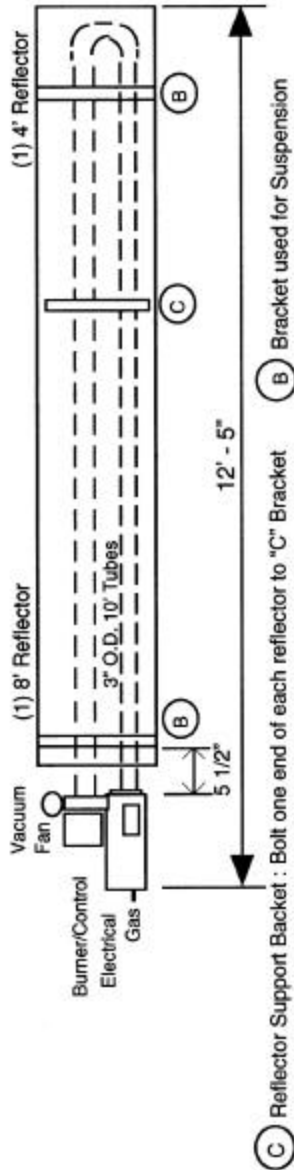

(C) Reflector Support Bracket : Bolt one end of each reflector to "C" Bracket (B) Bracket used for Suspension

BRACKET DETAIL

3" U-Tube "C" Bracket Profile 3" U-Tube "B" Bracket Profile

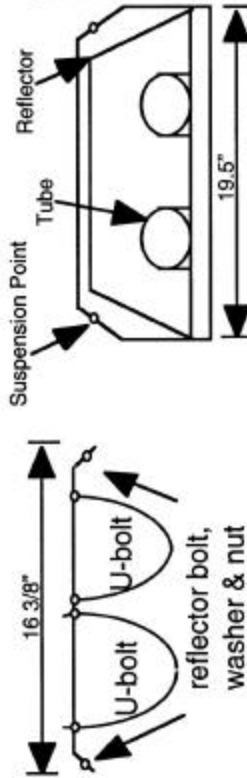

BURNER INSTALLATION DETAIL

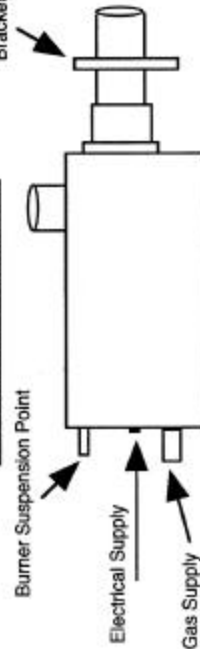

Lift From Bottom, Back of Burner While Tightening Allen Screws To Assure Burner Level, Attach Hanger Chain To Burner Suspension Point To Maintain Level and Provide Additional Support

All Tubing is color coded on the end to identify its composition

Red Stainless Steel
Yellow Aluminized Steel
Blue Mild Steel

Gas Supply Connection.....1/2" NPT male	Minimum
Gas supply pressure (inches w.c.)	Maximum
Natural Gas.....10.0	6.5
L.P.Gas.....14.0	11.0
Electrical Supply.....120V, single phase, 60Hz	
Current Rating.....1.2A max. (Burner 0.3A; Fan 0.9A)	
Ignition.....Electronic program start-up with spark ignition	

Model Number	BTH/HR	OPERATING GAS PRESSURE	
		Natural Gas	LP Gas
SGX/SA/CW/ER/AL/SC12S2C	40,000	1.9" wc	6.7" wc
SGX/SA/CW/ER/AL/SC15S2C	50,000	3.0" wc	10.5" wc
SGX/SA/CW/ER/AL/SC18S2C	60,000	2.4" wc	6.7" wc
SGX/SA/CW/ER/AL/SC22S2C	75,000	3.8" wc	10.5" wc

SERIES	COMBUSTION TUBE	REMAINING TUBE	REFLECTORS
SGX	Stainless Steel	Stainless Steel	Stainless Steel
SA	Stainless Steel	Stainless Steel	Aluminum
CW	Aluminized Steel	Aluminized Steel	Stainless Steel
ER	Aluminized Steel	Mild Steel	Stainless Steel
AL	Aluminized Steel	Aluminized Steel	Aluminum
SC	Aluminized Steel	Mild Steel	Aluminum

3" Ultimate Products Gas Infrared Heater- 40,000 - 75,000 btu Model "U30"

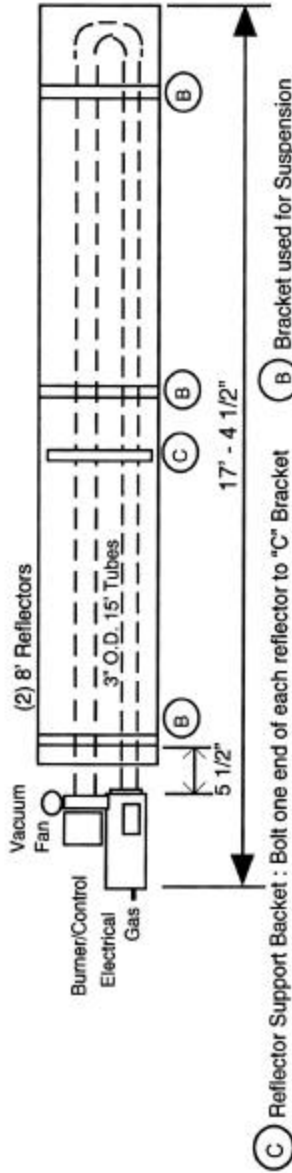

(C) Reflector Support Bracket : Bolt one end of each reflector to "C" Bracket (B) Bracket used for Suspension

BRACKET DETAIL

3" U-Tube "C" Bracket Profile 3" U-Tube "B" Bracket Profile

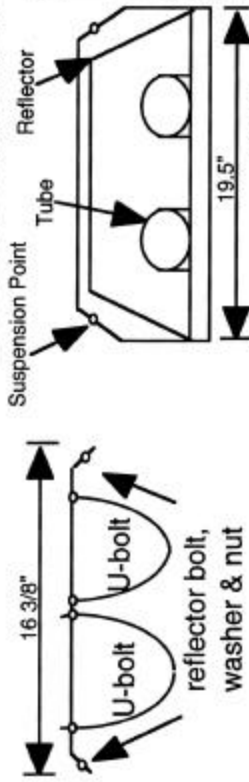

BURNER INSTALLATION DETAIL

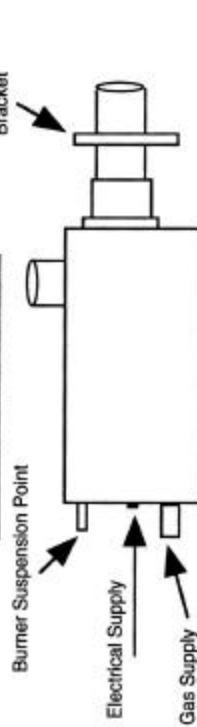

Lift From Bottom, Back of Burner While Tightening Allen Screws To Assure Burner Level, Attach Hanger Chain To Burner Suspension Point To Maintain Level and Provide Additional Support

All Tubing is color coded on the end to identify its composition

Red Stainless Steel
Yellow Aluminized Steel
Blue Mild Steel

Gas Supply Connection	1/2" NPT male
Gas supply pressure (inches w.c.)	Maximum 6.5 Minimum 11.0
Natural Gas	14.0
L.P. Gas	11.0
Electrical Supply	120V, single phase 60Hz
Current Rating	1.2A max. (Burner 0.3A; Fan 0.9A)
Ignition	Electronic program start-up with spark ignition

Model Number	BTH/HR	OPERATING GAS PRESSURE	
		Natural Gas	LP Gas
SGX/SA/CW/ERIAL/SC12U30	40,000	1.9" WC	6.7" WC
SGX/SA/CW/ERIAL/SC15U30	50,000	3.0" WC	10.5" WC
SGX/SA/CW/ERIAL/SC18U30	60,000	2.4" WC	6.7" WC
SGX/SA/CW/ERIAL/SC22U30	75,000	3.8" WC	10.5" WC

SERIES	COMBUSTION TUBE	REMAINING TUBE	REFLECTORS
SGX	Stainless Steel	Stainless Steel	Stainless Steel
SA	Stainless Steel	Stainless Steel	Aluminum
CW	Aluminized Steel	Aluminized Steel	Stainless Steel
ER	Aluminized Steel	Mild Steel	Stainless Steel
AL	Aluminized Steel	Aluminized Steel	Aluminum
SC	Aluminized Steel	Mild Steel	Aluminum

3" Ultimate Products Gas Infrared Heater - 40,000 - 75,000 btu Model "U40"

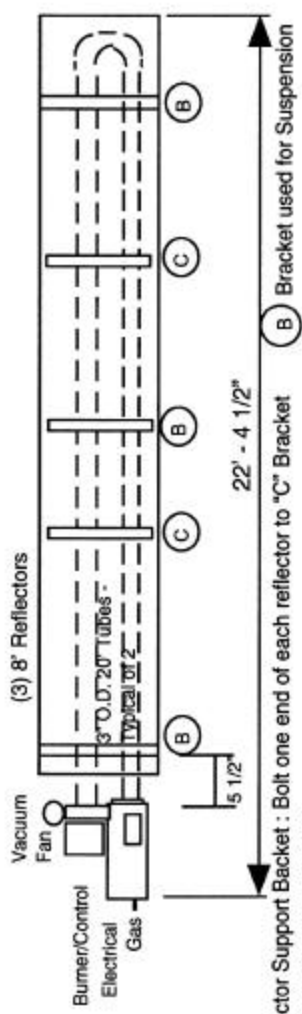

C Reflector Support Bracket : Bolt one end of each reflector to "C" Bracket **B** Bracket used for Suspension

BRACKET DETAIL

3" U-Tube "C" Bracket Profile 3" U-Tube "B" Bracket Profile

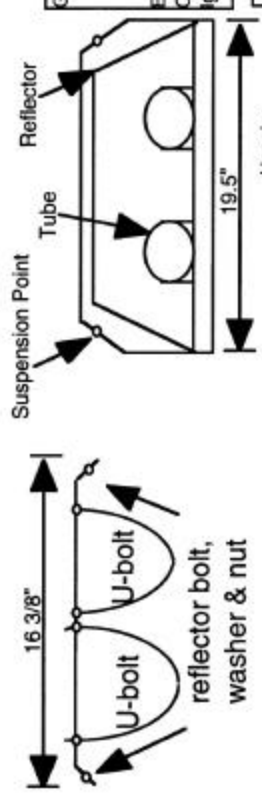

Gas Supply Connection.....1/2" NPT male	Minimum
Gas supply pressure (inches w.c.) Maximum	6.5
Natural Gas.....10.0	11.0
L.P.Gas.....14.0	
Electrical Supply.....120V, single phase, 60Hz	
Current Rating.....1.2A max. (Burner 0.3A; Fan 0.9A)	
Ignition.....Electronic program start-up with spark ignition	

Model Number	BTH/HR	OPERATING GAS PRESSURE	
		Natural Gas	LP Gas
SGX/SA/CW/ER/AL/SC12U40	40,000	1.9" wc	6.7" wc
SGX/SA/CW/ER/AL/SC15U40	50,000	3.0" wc	10.5" wc
SGX/SA/CW/ER/AL/SC18U40	60,000	2.4" wc	6.7" wc
SGX/SA/CW/ER/AL/SC22U40	75,000	3.8" wc	10.5" wc

SERIES	COMBUSTION TUBE	REMAINING TUBE	REFLECTORS
SGX	Stainless Steel	Stainless Steel	Stainless Steel
SA	Stainless Steel	Stainless Steel	Aluminum
CW	Aluminized Steel	Aluminized Steel	Stainless Steel
ER	Aluminized Steel	Mild Steel	Stainless Steel
AL	Aluminized Steel	Aluminized Steel	Aluminum
SC	Aluminized Steel	Mild Steel	Aluminum



BURNER INSTALLATION DETAIL

Lift From Bottom, Back of Burner While Tightening Allen Screws To Assure Burner Level, Attach Hanger Chain To Burner Suspension Point To Maintain Level and Provide Additional Support

All Tubing is color coded on the end to identify its composition

Red Stainless Steel
Yellow Aluminized Steel
Blue Mild Steel



3" Ultimate Products Gas Infrared Heater - 40,000 - 75,000 btu Model "U50"

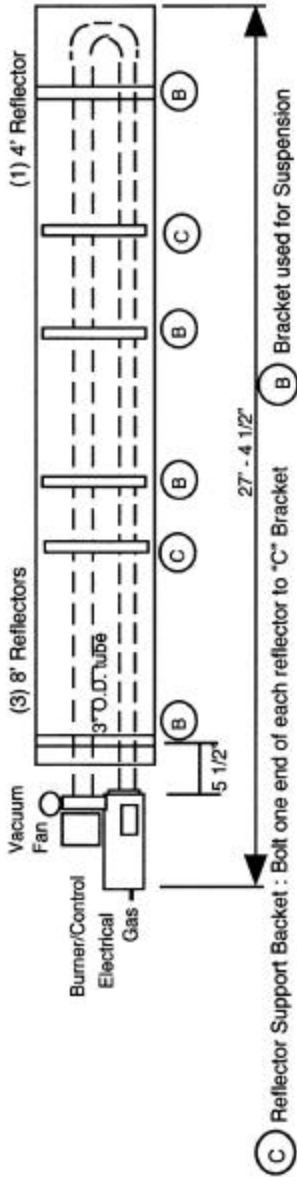

Ⓒ Reflector Support Bracket : Bolt one end of each reflector to "C" Bracket Ⓑ Bracket used for Suspension

BRACKET DETAIL

3" U-Tube "C" Bracket Profile 3" U-Tube "B" Bracket Profile

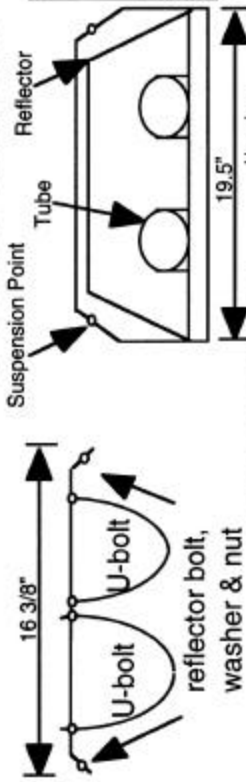

BURNER INSTALLATION DETAIL

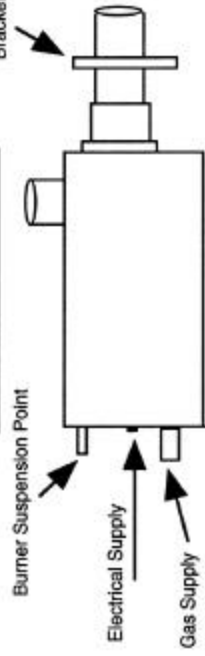

Lift From Bottom, Back of Burner While Tightening Allen Screws To Assure Burner Level. Attach Hanger Chain To Burner Suspension Point To Maintain Level and Provide Additional Support

All Tubing is color coded on the end to identify its composition

Red Stainless Steel
Yellow Aluminized Steel
Blue Mild Steel

Gas Supply Connection	1/2" NPT male	Minimum	6.5
Gas supply pressure (inches w.c.)	Maximum	14.0	11.0
Natural Gas	14.0		
L.P. Gas	14.0		
Electrical Supply	120V, single phase, 60Hz		
Current Rating	1.2A max. (Burner 0.3A; Fan 0.9A)		
Ignition	Electronic program start-up with spark ignition		

Model Number	BTU/Hr	OPERATING GAS PRESSURE	
		Natural Gas	LP Gas
SGX/SA/CW/ER/AL/SC12U50	40,000	1.9" WC	6.7" WC
SGX/SA/CW/ER/AL/SC15U50	50,000	3.0" WC	10.5" WC
SGX/SA/CW/ER/AL/SC18U50	60,000	2.4" WC	6.7" WC
SGX/SA/CW/ER/AL/SC22U50	75,000	3.8" WC	10.5" WC

SERIES	COMBUSTION TUBE	REMAINING TUBE	REFLECTORS
SGX	Stainless Steel	Stainless Steel	Stainless Steel
SA	Stainless Steel	Stainless Steel	Aluminum
CW	Aluminized Steel	Aluminized Steel	Stainless Steel
ER	Aluminized Steel	Mild Steel	Stainless Steel
AL	Aluminized Steel	Aluminized Steel	Aluminum
SC	Aluminized Steel	Mild Steel	Aluminum



4" Ultimate Products Gas Infrared Heater - 100,000 btu - 150,000 btu Model "U20"

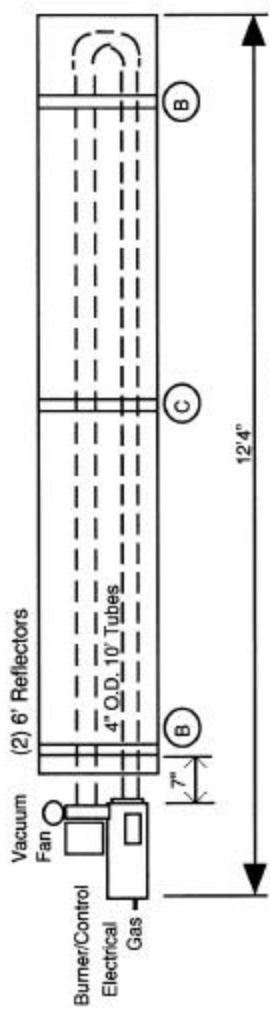

C Reflector Support Bracket : Bolt one end of each reflector to "C" Bracket
B Bracket used for Suspension

BRACKET DETAIL

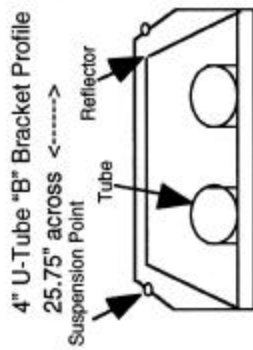
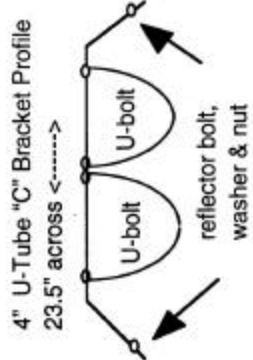

Gas Supply Connection.....	1/2" NPT male	Minimum
Gas supply pressure (inches w.c.).....	Maximum	6.5
Natural Gas.....	10.0	11.0
L.P. Gas.....	14.0	
Electrical Supply.....	120V, single phase, 60Hz	
Current Rating.....	1.2A max. (Burner 0.3A; Fan 0.9A)	
Ignition.....	Electronic program start-up with spark ignition	

BURNER INSTALLATION DETAIL

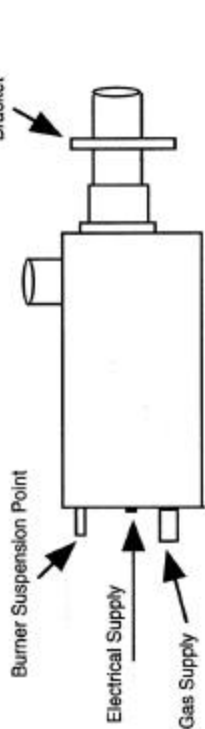

Lift From Bottom, Back of Burner While Tightening Allen Screws To Assure Burner Level, Attach Hanger Chain To Burner Suspension Point To Maintain Level and Provide Additional Support

All Tubing is color coded on the end to identify its composition

- Red Stainless Steel
- Yellow Aluminized Steel
- Blue Mild Steel

Model Number	BTH/HR	OPERATING GAS PRESSURE	
		Natural Gas	LP Gas
SGX/SA/CW/ER/AL/SC28U20	100,000	4.9" wc	10" wc
SGX/SA/CW/ER/AL/SC38U20	130,000	4.9" wc	10" wc
SGX/SA/CW/ER/AL/SC44U20	150,000	4.6" wc	10" wc

SERIES	COMBUSTION TUBE	REMAINING TUBE	REFLECTORS
SGX	Stainless Steel	Stainless Steel	Stainless Steel
SA	Stainless Steel	Stainless Steel	Aluminum
CW	Aluminized Steel	Aluminized Steel	Stainless Steel
ER	Aluminized Steel	Mild Steel	Stainless Steel
AL	Aluminized Steel	Aluminized Steel	Aluminum
SC	Aluminized Steel	Mild Steel	Aluminum

4" Ultimate Products Gas Infrared Heater - 100,000 btu - 130,000 btu Model "U30"

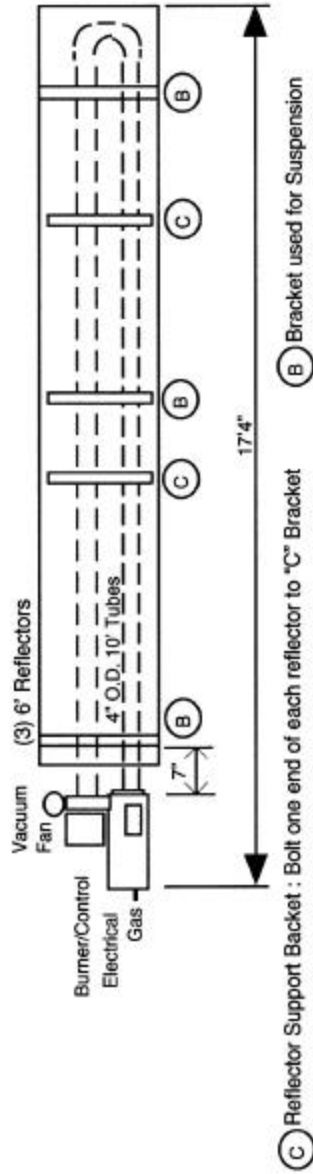

(C) Reflector Support Bracket : Bolt one end of each reflector to "C" Bracket (B) Bracket used for Suspension

BRACKET DETAIL

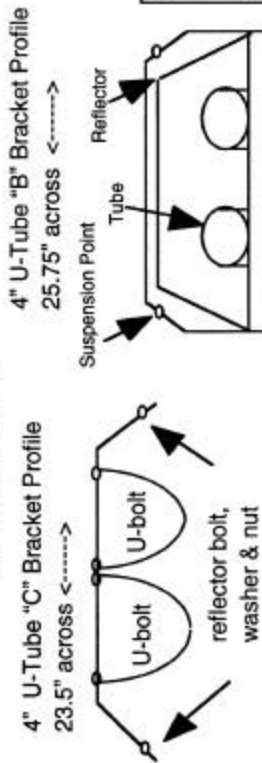

BURNER INSTALLATION DETAIL

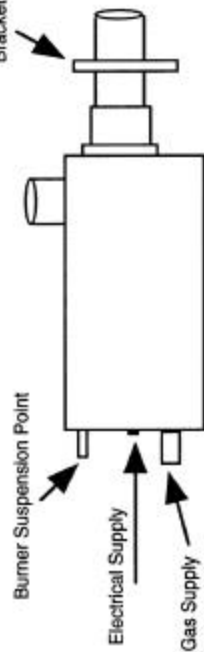

Lift From Bottom, Back of Burner While Tightening Allen Screws To Assure Burner Level, Attach Hanger Chain To Burner Suspension Point To Maintain Level and Provide Additional Support

All Tubing is color coded on the end to identify its composition

- Red Stainless Steel
- Yellow Aluminized Steel
- Blue Mild Steel

Gas Supply Connection.....	1/2" NPT male
Gas supply pressure (inches w.c.)	Maximum 6.5 Minimum 11.0
Natural Gas.....	10.0
L.P. Gas.....	14.0
Electrical Supply.....	120V, single phase, 60Hz
Current Rating.....	1.2A max. (Burner 0.3A; Fan 0.9A)
Ignition.....	Electronic program start-up with spark ignition

Model Number	BTH/HR	OPERATING GAS PRESSURE	
		Natural Gas	LP Gas
SGX/SA/CW/ER/AL/SC29U30	100,000	4.9" wc	10" wc
SGX/SA/CW/ER/AL/SC38U30	130,000	4.9" wc	10" wc

SERIES	COMBUSTION TUBE	REMAINING TUBE	REFLECTORS
SGX	Stainless Steel	Stainless Steel	Stainless Steel
SA	Stainless Steel	Stainless Steel	Aluminum
CW	Aluminized Steel	Aluminized Steel	Stainless Steel
ER	Aluminized Steel	Mild Steel	Stainless Steel
AL	Aluminized Steel	Aluminized Steel	Aluminum
SC	Aluminized Steel	Mild Steel	Aluminum

4" Ultimate Products Gas Infrared Heater- 100,000 btu - 150,000 btu Model "U35"

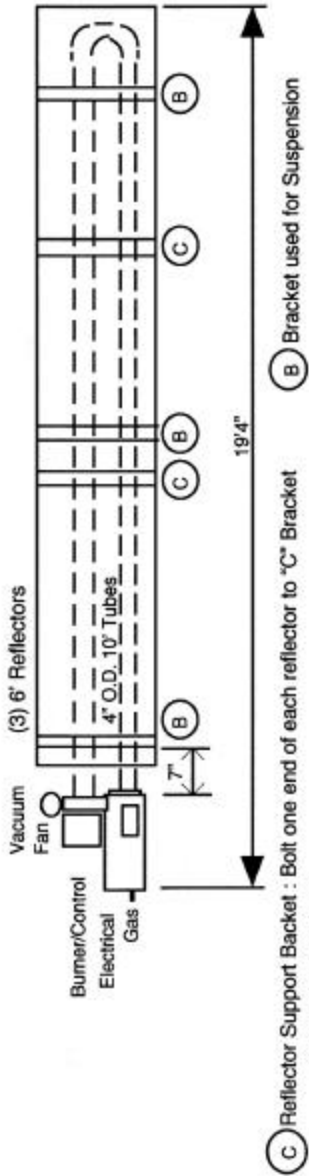

BRACKET DETAIL

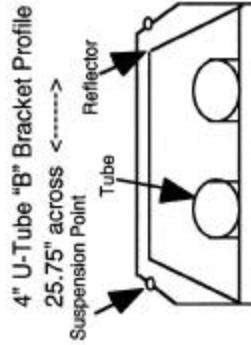
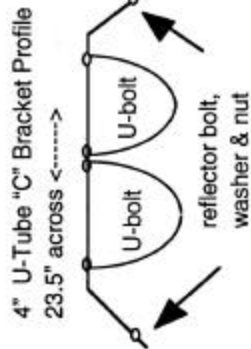

Gas Supply Connection.....1/2" NPT male	Minimum
Gas supply pressure (inches w.c.)	6.5
Natural Gas.....	10.0
L.P. Gas.....	14.0
Electrical Supply.....120V, single phase, 60Hz	
Current Rating.....1.2A max. (Burner 0.3A; Fan 0.9A)	
Ignition.....Electronic program start-up with spark ignition	

Model Number	BTH/HR	OPERATING GAS PRESSURE	
		Natural Gas	LP Gas
SGX/SA/CW/ER/AL/SC29U35	100,000	4.9" wc	10" wc
SGX/SA/CW/ER/AL/SC38U35	130,000	4.9" wc	10" wc
SGX/SA/CW/ER/AL/SC44U35	150,000	4.6" wc	10" wc

SERIES	COMBUSTION TUBE	REMAINING TUBE	REFLECTORS
SGX	Stainless Steel	Stainless Steel	Stainless Steel
SA	Stainless Steel	Stainless Steel	Aluminum
CW	Aluminized Steel	Aluminized Steel	Stainless Steel
ER	Aluminized Steel	Mild Steel	Stainless Steel
AL	Aluminized Steel	Aluminized Steel	Aluminum
SC	Aluminized Steel	Mild Steel	Aluminum

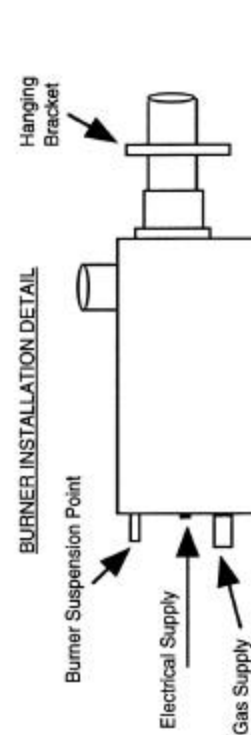

Lift From Bottom, Back of Burner While Tightening Allen Screws To Assure Burner Level, Attach Hanger Chain To Burner Suspension Point To Maintain Level and Provide Additional Support

All Tubing is color coded on the end to identify its composition

Red Stainless Steel
Yellow Aluminized Steel
Blue Mild Steel

4" Ultimate Products Gas Infrared Heater - 100,000 btu - 150,000 btu Model "U40"

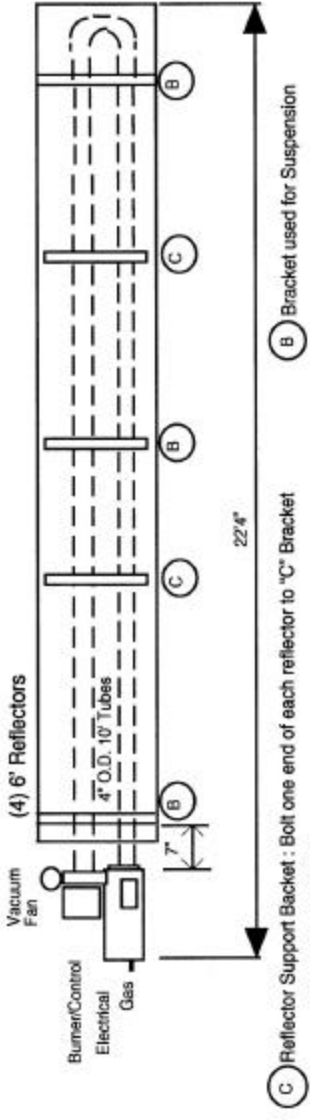

BRACKET DETAIL
 (C) Reflector Support Bracket : Bolt one end of each reflector to "C" Bracket
 (B) Bracket used for Suspension

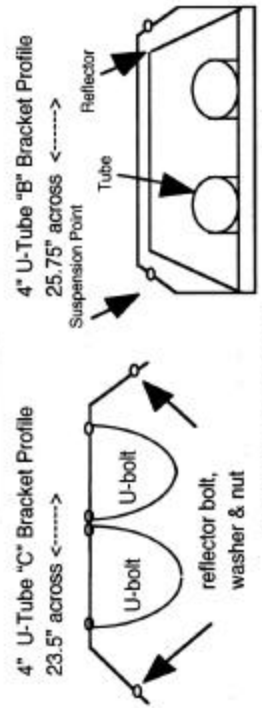

4" U-Tube "C" Bracket Profile
 23.5" across
 4" U-Tube "B" Bracket Profile
 25.75" across
 Suspension Point
 Reflector
 Tube

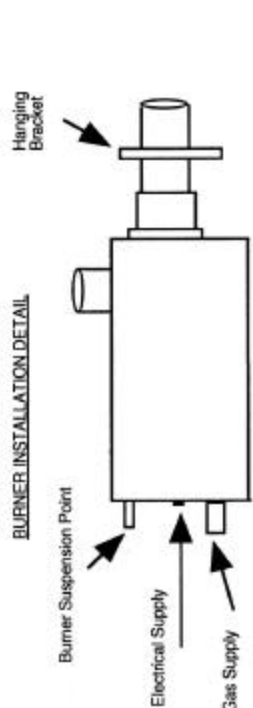

BURNER INSTALLATION DETAIL
 Lift From Bottom, Back of Burner While Tightening Allen Screws To Assure Burner Level. Attach Hanger Chain To Burner Suspension Point To Maintain Level and Provide Additional Support

All Tubing is color coded on the end to identify its composition
 Red - Stainless Steel
 Yellow - Aluminized Steel
 Blue - Mild Steel

Gas Supply Connection.....1/2" NPT male	Minimum
Gas supply pressure (inches w.c.)	Maximum
Natural Gas.....	10.0
L.P. Gas.....	14.0
Electrical Supply.....	120V, single phase, 60Hz
Current Rating.....	1.2A max. (Burner 0.3A; Fan 0.9A)
Ignition.....	Electronic program start-up with spark ignition

Model Number	BTHHR	OPERATING GAS PRESSURE
SGX/SA/CW/ER/AL/SC29U40	100,000	Natural Gas 4.9" wc LP Gas 10" wc
SGX/SA/CW/ER/AL/SC38U40	130,000	Natural Gas 4.9" wc LP Gas 10" wc
SGX/SA/CW/ER/AL/SC44U40	150,000	Natural Gas 4.6" wc LP Gas 10" wc

SERIES	COMBUSTION TUBE	REMAINING TUBE	REFLECTORS
SGX	Stainless Steel	Stainless Steel	Stainless Steel
SA	Stainless Steel	Stainless Steel	Aluminum
CW	Aluminized Steel	Aluminized Steel	Stainless Steel
ER	Aluminized Steel	Mild Steel	Stainless Steel
AL	Aluminized Steel	Aluminized Steel	Aluminum
SC	Aluminized Steel	Mild Steel	Aluminum

4" Ultimate Products Gas Infrared Heater - 100,000 btu - 150,000 btu Model "U45"

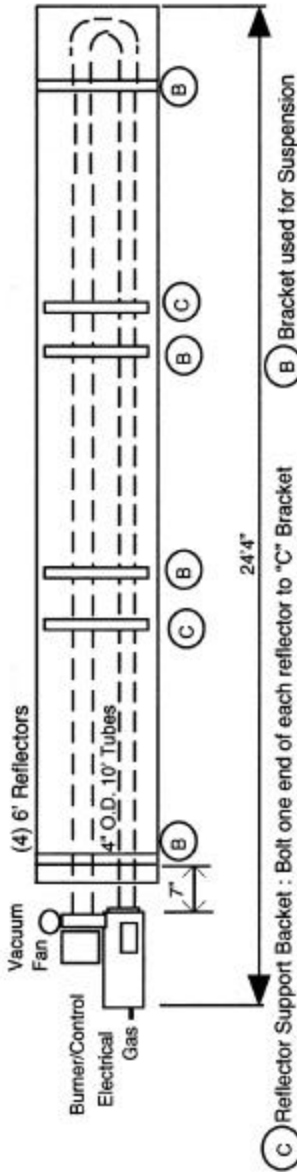

(C) Reflector Support Bracket : Bolt one end of each reflector to "C" Bracket
 (B) Bracket used for Suspension

BRACKET DETAIL

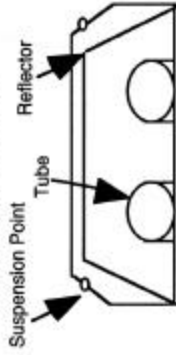
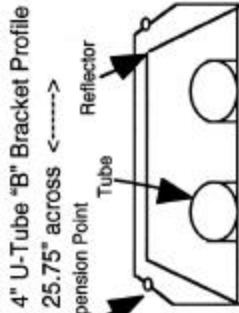
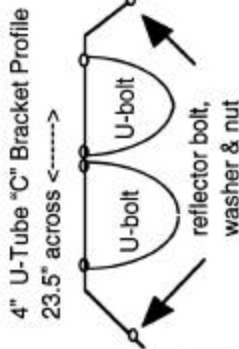

BURNER INSTALLATION DETAIL

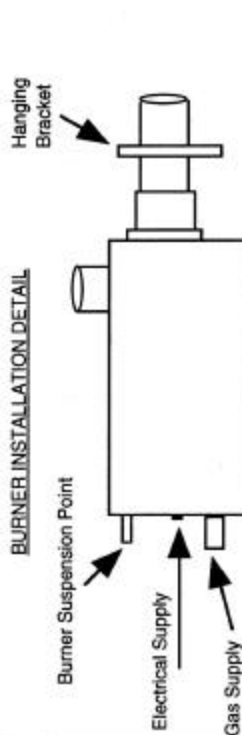

Lift From Bottom, Back of Burner While Tightening Allen Screws To Assure Burner Level, Attach Hanger Chain To Burner Suspension Point To Maintain Level and Provide Additional Support

All Tubing is color coded on the end to identify its composition

Red Stainless Steel
 Yellow Aluminized Steel
 Blue Mild Steel

Gas Supply Connection.....	1/2" NPT male
Gas supply pressure (inches w.c.)	Minimum 6.5 Maximum 10.0
Natural Gas.....	10.0
L.P. Gas.....	14.0
Electrical Supply.....	120V, single phase, 60-Hz
Current Rating.....	1.2A max. (Burner 0.3A; Fan 0.9A)
Ignition.....	Electronic program start-up with spark ignition

Model Number	BTH/HR	OPERATING GAS PRESSURE	
		Natural Gas	LP Gas
SGX/SA/CW/ER/AL/SC29U45	100,000	4.9" wc	10" wc
SGX/SA/CW/ER/AL/SC38U45	130,000	4.9" wc	10" wc
SGX/SA/CW/ER/AL/SC44U45	150,000	4.6" wc	10" wc

SERIES	COMBUSTION TUBE	REMAINING TUBE	REFLECTORS
SGX	Stainless Steel	Stainless Steel	Stainless Steel
SA	Stainless Steel	Stainless Steel	Aluminum
CW	Aluminized Steel	Aluminized Steel	Stainless Steel
ER	Aluminized Steel	Mild Steel	Stainless Steel
AL	Aluminized Steel	Aluminized Steel	Aluminum
SC	Aluminized Steel	Mild Steel	Aluminum

4" Ultimate Products Gas Infrared Heater- 100,000 btu - 150,000 btu Model "U50"

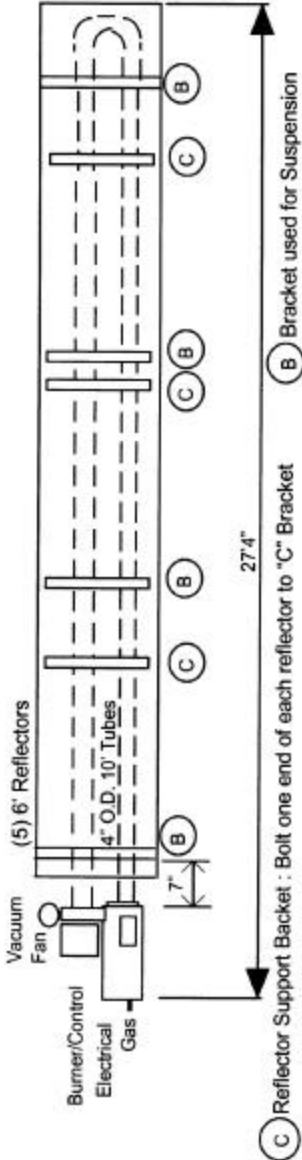

BRACKET DETAIL

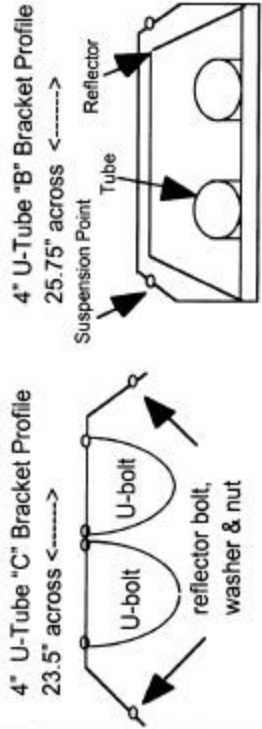

Gas Supply Connection.....	1/2" NPT male
Gas supply pressure (inches w.c.).....	Minimum 6.5 Maximum 10.0
Natural Gas.....	10.0
L.P. Gas.....	14.0 11.0
Electrical Supply.....	120V, single phase, 60Hz
Current Rating.....	1.2A max. (Burner 0.3A; Fan 0.9A)
Ignition.....	Electronic program start-up with spark ignition

BURNER INSTALLATION DETAIL

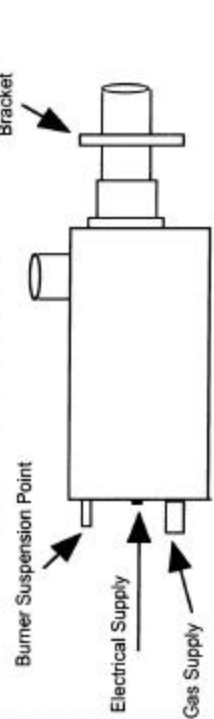

All Tubing is color coded on the end to identify its composition

Red Stainless Steel
Yellow Aluminized Steel
Blue Mild Steel

Model Number	BTH/HR	OPERATING GAS PRESSURE	
		Natural Gas	LP Gas
SGX/SA/CW/ER/AL/SC29U50	100,000	4.9" wc	10" wc
SGX/SA/CW/ER/AL/SC38U50	130,000	4.9" wc	10" wc
SGX/SA/CW/ER/AL/SC44U50	150,000	4.6" wc	10" wc

SERIES	COMBUSTION TUBE	REMAINING TUBE	REFLECTORS
SGX	Stainless Steel	Stainless Steel	Stainless Steel
SA	Stainless Steel	Stainless Steel	Aluminum
CW	Aluminized Steel	Aluminized Steel	Stainless Steel
ER	Aluminized Steel	Mild Steel	Stainless Steel
AL	Aluminized Steel	Aluminized Steel	Aluminum
SC	Aluminized Steel	Mild Steel	Aluminum

APPENDIX 'B'

Mounting Clearances for Car Washes

Clearances to combustibles behind the heater and at the non-burner end of the heater:

Allow 1 foot between the back of the reflector and walls/ceilings constructed with combustible materials. Combustibles include wood and plastics. Treat glass as a combustible, too. Steel and concrete are non-combustibles—you can mount to these surfaces with zero clearance. For tighter-fitting installations, use radiant shields made of stainless steel (available from Radiant Systems). For tight fits at the non-burner end of the heater, use an end cap (available from Radiant Systems).

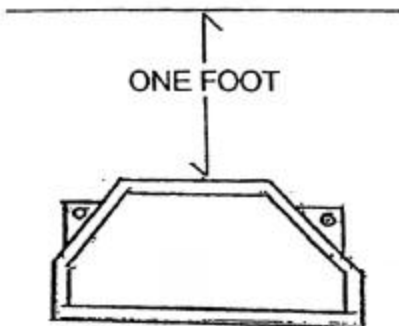

Clearances to combustibles in front of the heater:

Metal washing equipment is not a combustible, but fiberglass panels, insulated electrical wiring, and hoses on the equipment are combustibles. When possible, follow the standard chart in the owner's manual for clearances between the tube and combustibles in front of the heater. When it's not possible to mount with standard clearances, use radiant shields made of stainless steel to guard combustibles that are within three feet of the heating tube.

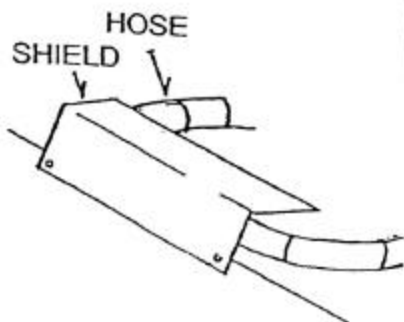

Mounting height:

Mount the heater above the wash equipment. Generally, mount as high as possible. In self service bays and personnel areas, mount the equipment so the tube is out of reach.

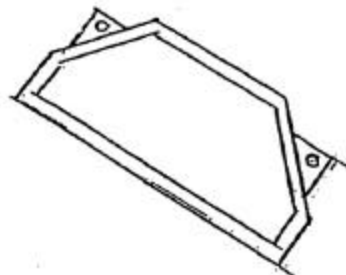

Down the centerline or across the bay:

Hang the brackets level to spread heat from the centerline of the bay. Hang the brackets at angle to reflect heat down and across the bay. Go up or down one or more chain-link to adjust the tilt from 0 degrees to 55 degrees.

ANGLE MOUNT 45°

FLAT MOUNT — 0°

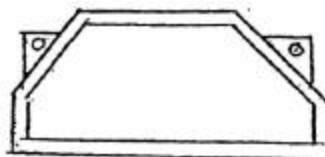

Warning: If you are mounting along a side wall, angle the brackets 45-degrees.

Note: With end caps, side wall to heater and clearances can be reduced to less than 1 foot

IMPORTANT

Turbulators are required on the following heaters:

3" tube less than 25 ft. total

4" tube less than 40 ft. total

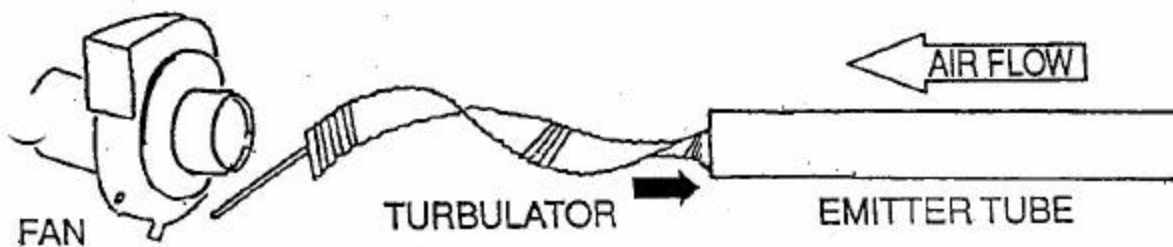

Insert the turbulator into the proper tube: the EMITTER tube!

To install the turbulator:

1. Insert the turbulator into the last leg of the tube before the fan.
(Use the push rod to force it all the way in.)
2. Put the fan on.

**DO NOT INSERT THE TURBULATOR INTO THE BURNER TUBE (HOT LEG).
FIRE AND/OR EQUIPMENT FAILURE WILL RESULT.**



Please call (800) 542-7221 for technical assistance.



For All Sales, Parts, or Service:

Ultimate Products, Inc.

2319 Laurelbrook Street

Raleigh, NC 27604 USA

Toll-Free: (800) 542-7221

Phone: (919) 836-1627

Fax: (919) 834-4526

www.ultimate-products.com